

MODEL DA4

(Formerly DA3/4)

DIRECT-ACTING, PRESSURE LOADED PRESSURE REDUCING REGULATOR

(Model DA3 was identical to DA4 except that the DA3 did not include a lower return spring.)

SECTION I

I. DESCRIPTION AND SCOPE

Model DA4 is a pressure reducing regulator used to control downstream (outlet or P2) pressure. Sizes are 1/2" (DN15), 3/4" (DN20), 1" (DN25), 1-1/4" (DN32), 1-1/2" (DN40), 2" (DN50), 3" (DN80) and 4" (DN100). With proper trim utilization, the unit is suitable for liquid, gaseous, or steam service. Refer to Technical Bulletin DA4-TB for design conditions and selection recommendations. (**NOTE:** *This product was formerly identified as a Model D4; a Model DA4 and D4 are the same.*)

This manual does not include instructions related to the various methods of pressure loading a Model DA4 main valve.

SECTION II

II. REFERENCES

Refer to Technical Bulletin DA4-TB and DAG-TB for technical specifications for this regulator.

ABBREVIATIONS

| | | |
|-----|---|---------------------|
| CW | – | Clockwise |
| CCW | – | Counter Clockwise |
| ITA | – | Inner Trim Assembly |

SECTION III

III. INSTALLATION

CAUTION

For welded installations, all internal trim parts, seals and diaphragm(s) must be removed from regulator body prior to welding into pipeline. The heat of fusion welding will damage non-metallic parts if not removed. **NOTE:** This does not apply to units equipped with extended pipe nipples.

1. Regulator may be rotated around pipe axis 360 degrees. For ease of maintenance, the recommended position is with the cover dome (25) upwards. In liquid service it is recommended that the cover dome (25) be oriented downwards, and that a customer supplied and installed vent valve be provided at the external sensing connection to bleed-off trapped gas/air under the diaphragm.
2. Provide space below, above, and around regulator for removal of parts during maintenance.
3. Install block valves and pressure gauges to provide means for adjustment, operation, bypass, or removal of the regulator. A pipeline strainer is recommended before inlet to remove typical pipeline debris from entering valve and damaging internal "soft goods", primarily the dynamic seal.

CAUTION

Installation of adequate overpressure protection is recommended to protect the regulator from overpressure and all downstream equipment from damage in the event of regulator failure.

4. Downstream Sensing Installation Considerations – Internal or External Sensing:
 - a. The regulator may be installed with internal or external sensing. Unless otherwise specified, the regulator is supplied by factory with internal sensing. The regulator may be converted in the field to external sensing. (See Section VII Maintenance, Part H – Converting Internal/ External Sensing.
 - b. Reference DAG-TB, Table DAG-11 for recommendations for applying external pressure sensing.
 - c. For internal sensing, no external line is required. For external sensing, use an external control line. The line is connected from the 1/4" (DN8) NPT tap (Port 5 – See Fig. 6) on the side of the body diaphragm flange to a pressure tap downstream of the regulator. Use 1/4" or 3/8" (DN8 or 10) outer diameter tubing

or 3/8" (DN10) pipe having an inner diameter equivalent to Schedule 40 pipe.

- d. For condensable vapors (i.e. steam) slope the external sensing line downward 2 to 5 degrees to outlet piping to prevent water pockets, which allows the diaphragm chamber to always be self draining. The external sensing line may be sloped upward for liquids or gases.

⚠ CAUTION

DO NOT HYDROSTATIC TEST THROUGH AN INSTALLED UNIT; ISOLATE REGULATOR FROM TEST. The "OUTLET RATING" as printed on the nameplate is the recommended "upper operating limit" for the sensing diaphragm. Higher pressures could cause internal damage. In addition, note on the nameplate that the Inlet and Outlet pressure and temperature ratings are at different levels.

⚠ CAUTION

Installation of adequate overpressure protection is recommended to protect the regulator from overpressure and all downstream equipment from damage in the event of regulator failure.

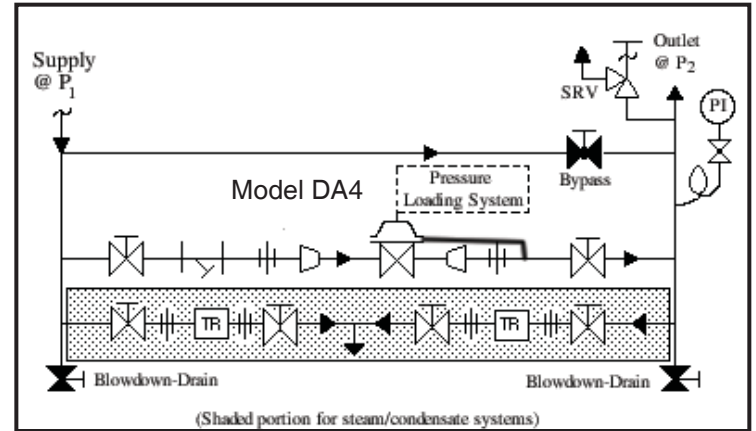

SECTION IV

IV. PRINCIPLE OF OPERATION

1. When a loading pressure – P_{Load} – is applied to the top side of a diaphragm, the outlet controlled pressure – P_2 – will balance at approximately .90 – .98 of the loading pressure - P_L . (**NOTE:** *Fluctuations in P_1 – Inlet Pressure will cause a deviation in P_2 – Outlet Pressure due to inverse sympathetic ratio effect.*) See Section VIII.
2. Movement occurs as pressure variations register on the diaphragm. The registering pressure is the outlet, P_2 , or downstream pressure. The loading

pressure fluid opposes diaphragm movement. As outlet pressure drops, the loading pressure pushes the diaphragm down, opening the port; as outlet pressure increases, the diaphragm pushes up and the port opening closes.

3. A diaphragm failure will tend to cause the regulator to fall below setpoint. A loss of loading pressure while inlet pressure is imposed will cause the regulator to fail close. A complete diaphragm failure will cause the inlet process fluid to mix with the loading fluid.

SECTION V

V. STARTUP

1. Start with the block valves closed.
2. Adjust the loading system pressure control device so that main regulator is trying to be controlled at 0 psig pressure.
3. If it is a "hot" piping system, and equipped with a bypass valve, slowly open the bypass valve to preheat the system piping and to allow slow expansion of the piping. Ensure proper steam trap operation if installed. Closely monitor outlet (downstream) pressure via gauge to ensure not over-pressurizing. **NOTE:** *If no bypass valve is installed, extra caution should be used in starting up a cold system; i.e. do everything slowly.*

4. Crack open the outlet (downstream) block valve to approximately 10% full open.
5. Slowly open the inlet (upstream) block valve to about 25% open. Adjust the loading system pressure control device setpoint pressure upwards until the main valve is flowing. Observe the outlet pressure gauge to ensure not overpressurizing.
6. Continue to slowly open the inlet (upstream) block valve until fully open.
7. Continue to slowly open the outlet (downstream) block valve, especially when the downstream piping system isn't pressurized. If the outlet (downstream) pressure exceeds the desired pressure, close the inlet block valve and go to Step 2. Close bypass valve approximately 25%, and repeat procedure.
8. When flow is established steady enough that the outlet (downstream) block valve is fully open, begin to slowly close the bypass valve if installed.

⚠ CAUTION

Do not walk away and leave a bypassed regulator unattended!

9. Develop system flow to a level near its expected normal rate, and reset the regulator set point by adjusting the loading system pressure control setpoint to the desired outlet pressure level.

10. Reduce system flow to a minimum level and observe pressure set point. Outlet pressure will rise from the set point of Step 9 for a Model DA4. The maximum rise in outlet pressure on decreasing flow should not exceed the 10%. If it does, consult factory.

SECTION VI

VI. SHUTDOWN

1. Shutoff auxiliary loading pressure source, if supplied.
2. Shutoff inlet block valve.
3. Allow sufficient time for the line pressure downstream of the inlet block valve to bleed down.

4. Shutoff the outlet block valve.
5. Relieve the trapped upstream and downstream pressure and loading pressure.
6. The regulator may now be removed from the pipeline or disassembled for inspection and preventative maintenance while in-line.

SECTION VII

VII. MAINTENANCE

A. General:

WARNING

SYSTEM UNDER PRESSURE. Prior to performing any maintenance, isolate the regulator from the system and relieve all pressure. Failure to do so could result in personal injury.

1. The regulator may be serviced without removing the regulator from pipeline. The regulator is designed with quick-change trim to simplify maintenance.
2. Record the nameplate information to requisition repair parts for the regulator. The information should include: size, KM Product Code, Serial Number, and internal or external sensing. (**NOTE: Never both types of sensing.**) If external sensing is used, be sure that the external sensing line is connected.
3. Refer to Section X for recommended repair parts. Only use original equipment parts supplied by Cashco/KM for rebuilding or repairing regulators.
4. Owner should refer to owner's procedures for removal, handling, cleaning and disposal of nonreusable parts, i.e. gaskets, etc.
NOTE: On regulators originally supplied as "oxygen clean" – Opt-55, maintenance must include a level of cleanliness equal to Cashco cleaning standard #S-1134.

5. The Inner Trim is removed and replaced in the body (23) as an assemblage of parts. The Inner Trim Assembly, hereinafter called **ITA**, consists of the following parts:
A detailed view of the dynamic side seal parts is shown in Figure 1 on the next page.

| Item No. | Dynamic Seal Type | Part Description |
|----------|-------------------|------------------------------|
| 13 | All | Guide Bearing/Piston |
| 14 | All | Static Stem Seal |
| 14.1 | All | Upper Static Stem Seal |
| 14.2 | All | Middle Static Stem Seal |
| 14.3 | All | Lower Static Stem Seal |
| 15 | All | Cage O-ring Seal |
| 16 | CW,PW | Wiper |
| 17.1 | CW,PW | Wiper Washer |
| 17.2 | OR,CP, PR,UC | Camber Adjusting Washer * |
| 19 | All | Cage |
| 20 | All | Valve Plug |
| 21 | All | Seat Ring |
| 27 | All | Dynamic Side Seal |
| 27.1 | CP,CW | TFE Cap Seal |
| 27.2 | CP, CW | O-ring Energizer/Seal |
| 27.3 | UC | U-Cup Seal w/Metal Energizer |
| 27.4 | OR | O-Ring Seal |
| 27.5 | PR,PW | Piston Ring Seal |
| 27.6 | PR,PW | Piston Ring SST Energizer |

* Metal Diaphragm Only.

6. Sub-Sections B. through F. are for constructions that do **NOT** include any Opt-81 High Outlet Pressures with diaphragm support. These constructions are covered in Sub-Section G.

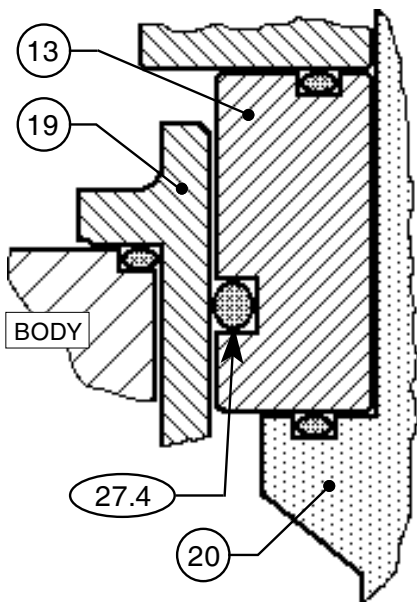

**Type OR — O-Ring
Dynamic Seal**

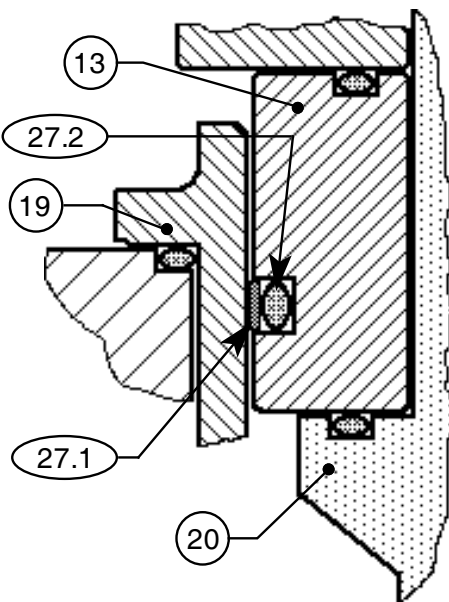

**Type CP — TFE Cap
Dynamic Seal**

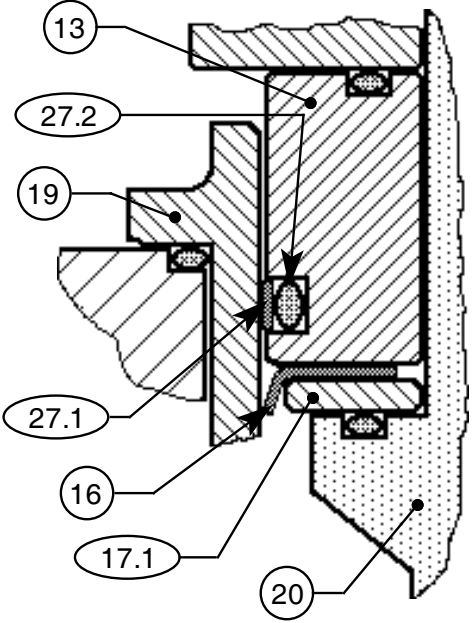

**Type CW — TFE Cap
Dynamic Seal + Wiper**

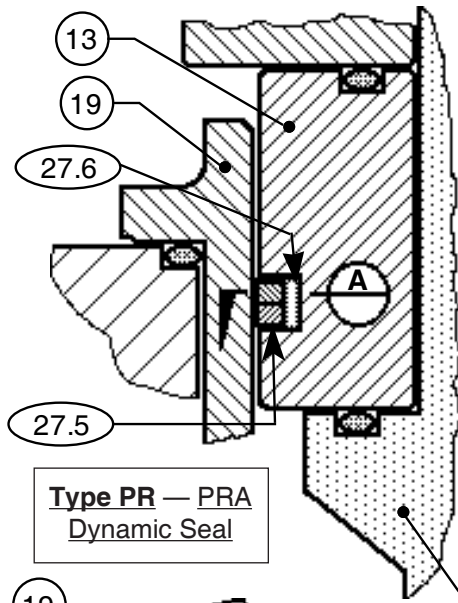

**Type PR — PRA
Dynamic Seal**

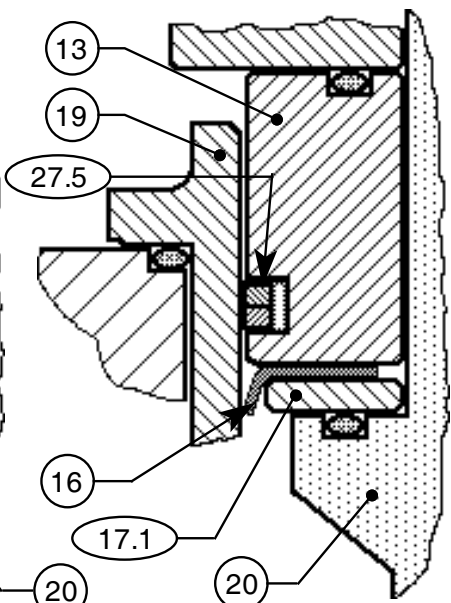

**Type PW — PRA Dynamic
Seal + Wiper**

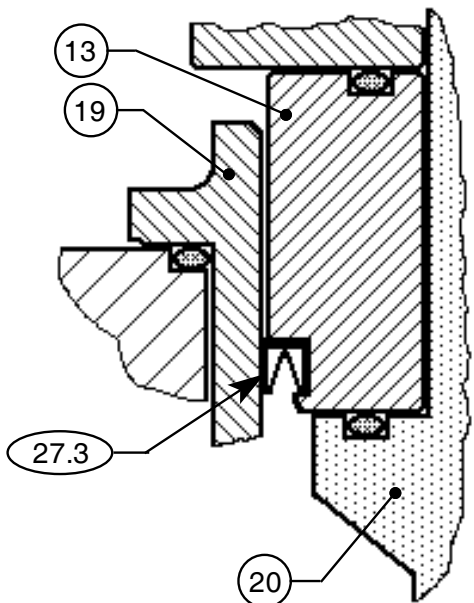

**Type UC — U-Cup
Dynamic Seal**

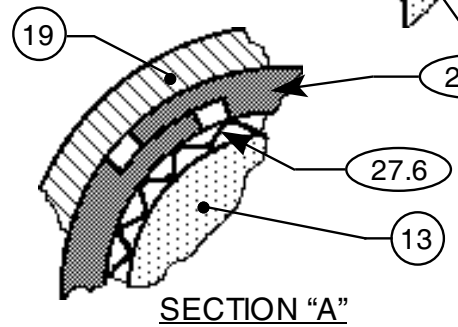

Figure 1: Dynamic Side Seals

B. Main Valve Disassembly:

WARNING

SYSTEM UNDER PRESSURE. Prior to performing any maintenance, isolate the regulator from the system and relieve all pressure. Failure to do so could result in personal injury.

1. Shut down the system in accordance with Section VI.
2. Disconnect the external sensing line, if installed.
3. Though it is possible to disassemble the valve unit while installed in a pipeline, it is recommended that maintenance be done in a shop when possible. The descriptions hereafter will assume shop disassembly. Remove valve from pipeline.
4. Place the valve unit in a vise with the cover dome (25) upwards.
5. Loosen the diaphragm flange bolts (11) and nuts (12) uniformly.
6. Place matchmarks on body (23) and cover dome (25) flanges. Remove the cover dome (25).
7. For composition diaphragm construction, hold the milled "flats" on top of the valve plug (20) stationary. Loosen and remove the diaphragm lock nut (7). **NOTE: Metal diaphragm constructions do NOT have a diaphragm lock nut (7).**
8. Remove upper diaphragm pressure plate (8).
9. Remove diaphragm(s) (9, 9.1, 9.2, 9.9) and o-ring upper stem seal (14.1). Examine diaphragm(s) to determine whether failed; determine if operating conditions are exceeding pressure, pressure drop or temperature limits.
10. For composition diaphragm construction, remove lower diaphragm pusher plate (10).
11. Evenly loosen the three cage cap screws (18) in single revolution increments. Regulator may contain a lower piston spring (22); the ITA should rise as the cage cap screws (18) are evenly backed out. A downwards holding force should be applied to the top of the piston-guide bearing (13) to prevent the ITA

from popping up as the last threads of the cage cap screws (18) are backed out.

12. Remove the ITA by pulling up on the valve plug (20). Set ITA aside.
13. Remove the lower piston spring (22), as applicable, from within the body (23).
14. Remove o-ring cage seal (15).
15. If supplied, remove internal sensing drilled plug (32) using 5/32" (4 mm) Allen wrench.
16. Remove body (23) from vise. Clean all reusable metal parts according to owner's procedures.

C. Disassembly of the ITA:

1. Units with Composition Diaphragm(s) (See Figure 2):
 - a. Pull the valve plug (20) downwards and out of the piston-guide bearing (13) and out of the cage's (19) bottom, while holding the cage (19).
 - b. Remove the piston-guide bearing (13) from the upper end of the cage (19).
 - c. Remove o-ring middle stem seal (14.2)

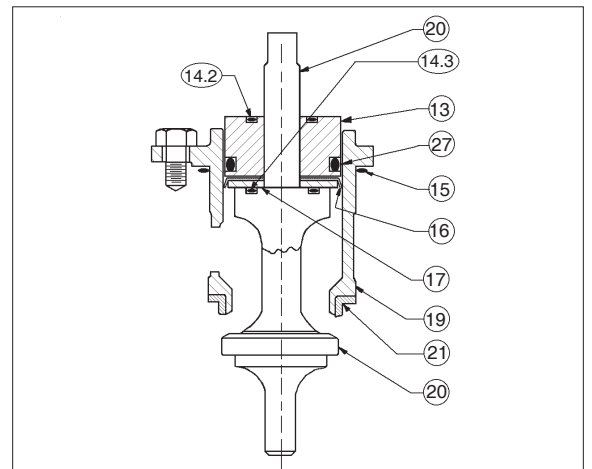

Figure 2: Assembled ITA, Composition Diaphragm Construction

- d. Examine the components (27.1, 27.2, 27.3, 27.4, 27.5, 27.6) of the dynamic side seal (27) mechanism to determine if significant leakage was occurring. If the dynamic side seal (27) shows signs of significant leakage, determine if operating conditions are exceeding pressure, pressure drop, or temperature limits. Remove dynamic side seal (27) compo-

nents. Special care should be taken when using “tools” to remove the components to ensure that no scratches are imparted to any portion of the piston-guide bearing (13) groove.

- e. Remove wiper seal (16), if supplied, from within cage (19).
 - f. Remove wiper washer (17.1) or camber adjusting washer (17.2), if supplied, from within cage (19).
 - g. Remove o-ring lower stem seal (14.3) from plug (20).
 - h. Remove seat ring (21); examine for signs of leakage. If seat ring (21) shows signs of significant leakage, determine if operating conditions of pressure, pressure drop, or temperature are exceeding limits.
2. Units with Metal Diaphragm(s) (See Figure 3):
- a. To disassemble the ITA, hold the lower part of the valve plug (20) in a bench vise; do not hold on the machined surface in the plug's (20) spindle area. (The spindle “slides” in the pressed-in-place lower guide bushing (24) and can not be allowed to be marred.)
 - b. Using a special double-posted spanner wrench fitting (to order see NOTE in Section X, Parts Ordering Information), turn the piston-guide bearing (13) CCW to loosen; piston-guide bearing (13) can be removed by hand after loosening.

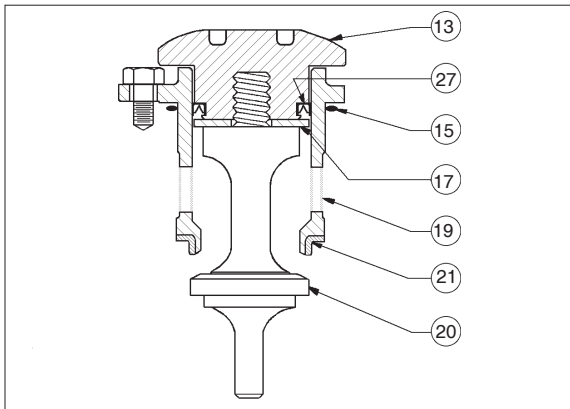

Figure 3: Assembled ITA,
Metal Diaphragm Construction

- c. Pull the valve plug (20) downwards and out of the piston-guide bearing (13) and out of the cage's (19) bottom while holding the cage (19).
- d. Remove the piston-guide bearing (13) from the upper end of cage (19).
- e. Examine the components (27.1, 27.2, 27.3, 27.4, 27.5, 27.6) of the dynamic side seal (27) mechanism to determine

if significant leakage was occurring. If the dynamic side seal (27) shows signs of significant leakage, determine if operating conditions are exceeding pressure, pressure drop, or temperature limits.

Remove dynamic side seal (27) components and discard. Special care should be taken when using “tools” to remove the components to ensure that no scratches are imparted to any portion of the piston-guide bearing (13) groove.

- f. Remove wiper seal (16), if supplied, from within cage (19).
 - g. Remove wiper washer (17.1) or camber adjusting washer (17.2), if supplied, from within cage (19).
 - h. Remove o-ring lower stem seal (14.3) from plug (20).
 - i. Remove seat ring (21); examine for signs of leakage. If seat ring (21) shows signs of significant leakage, determine if operating conditions of pressure, pressure drop, or temperature are exceeding limits.
3. Clean all reusable metal parts according to owner's procedures.

D. Inspection of Parts:

1. After inspection remove from the work area and discard the old “soft goods” parts (i.e. o-rings, diaphragms, seals, gaskets, etc.) after inspection. These parts **MUST** be replaced with factory supplied new parts.
2. Inspect the metal parts that will be reused. The parts should be free of surface contaminants, burrs, oxides, and scale. Rework and clean the parts as necessary. Surface conditions that affect the regulator performance are stated below; replace parts that can not be reworked or cleaned.
3. QC Requirements:
 - a. Valve plug (20);
 1. 16 rms finish on its seating surface for tight shutoff.
 2. No major defects on bottom guide spindle.
 - b. Cage (19);
 1. 16 rms finish on cylinder bore. No “ledges” formed due to wear from moving dynamic side seal (27) or wiper seal (16).
 - c. Lower guide bushing (24) (non-replaceable):
 1. 16 rms finish on bore.
 2. Max 0.015 inch (0.38 mm) clearance

between valve plug (20) spindle and lower guide bushing (24).

d. Internal sensing drilled plug (32);

1. Ensure that bore is minimum 0.125 inch (3.20 mm). Drill out as required.

4. Staging Material for Reassembly.

- a. Inspect and clean parts, as necessary, from the spare parts kit. (See Article VII .A.4. comments concerning cleaning for oxygen service.)
- b. Lay out all the regulator parts and check against the bill of material.

E. **Reassembly of the ITA:**

1. When replacing the optional wiper seal (16), the replacement wiper seal (16) is “pre-formed”. It may, however, require reforming. Under normal circumstances, this step may not be required. If needed, reform the wiper seal (16) by pressing the temporary assembly parts into the cage (19) backwards as shown in Figure 4. The wiper seal (16) is best left in this position overnight (minimum of two (2) hours) prior to reassembly.

2. After forming the wiper seal, remove parts (13, 16, 17) from cage (19) and disassemble the temporary assembly of Step 1. above.

3. Installation of dynamic side seal (27) (See Figure 1):

a. Type OR:

1. Stretch o-ring seal (27.4) over lower circumference of piston-guide bearing (13), taking care not to “cut” o-ring seal (27.4). Using thumbs, work the o-ring seal (27.4) up and into the groove of the piston-guide bearing (13). **NOTE:** A very slight amount of fluid and elastomer compatible lubricant is recommended as an installation aid.
2. For metal diaphragm construction, insert camber adjusting washer (17.2) into cage (19) and allow to rest in the bottom of the cage (19).
3. Position piston-guide bearing (13) over upper end of cage (19) properly oriented. Using thumbs, evenly press piston-guide bearing (13) into the cage (19), ensuring not to “cut” o-ring seal (27.4). Continue pressing piston-guide bearing (13) until in approximate final position.

b. Type CP:

1. Stretch o-ring energizer/seal (27.2) over lower circumference of piston-guide bearing (13), taking care not to “cut” o-ring energizer/seal (27.4). Using thumbs, work the o-ring en-

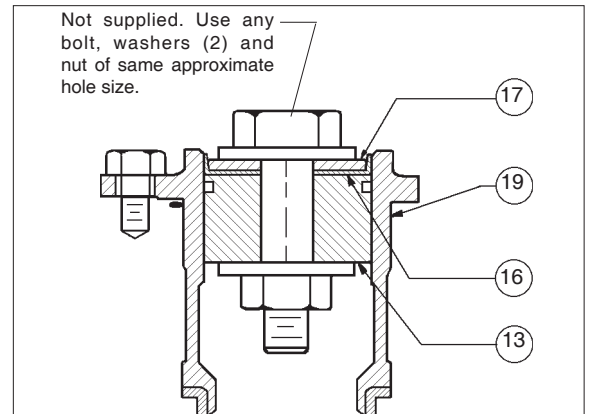

Figure 4: Temporary Assembly Parts

ergizer/seal (27.4) up and into the groove of the piston-guide bearing (13). **NOTE:** A very slight amount of fluid and elastomer compatible lubricant is recommended as an installation aid.

2. For metal diaphragm construction, insert camber adjusting washer (17.2) into cage (19) and allow to rest in the bottom of the cage (19).
3. Position TFE cap seal (27.1) ring with rectangular cross-section at end of piston-guide bearing (13). Stretch cap seal (27.1) over lower end of piston-guide bearing (13) using thumbs to work the cap seal (27.1) onto the piston-guide bearing (13). **DO NOT USE A TOOL FOR THIS STEP.** Continue pressing cap seal (27.1) upwards towards the groove until the cap seal (27.1) “snaps” into the groove of the piston-guide bearing (13).
4. Position piston-guide bearing (13) over and into upper end of cage (19) until the cap seal (27.1) edge touches the upper lip of the cage (19). While gently applying force to press the piston-guide bushing (13) into the cage (19), simultaneously use fingers to lightly press the cap seal (27.1) inwards into the groove of the piston-guide bearing (13) until the cap seal (27.1) “slips into” the cage (19). **DO NOT USE TOOLS, LUBRICANT, OR HEAVY FORCE TO ENGAGE THE CAP SEAL (27.1) INTO THE CAGE (19).** Do not press inwards on the Cap Seal (27.1) too much or the cap seal

(27.1) may slide out of its groove or the cap seal (27.1) can be damaged.

c. Type CW:

1. Stretch o-ring energizer/seal (27.2) over lower circumference of piston-guide bearing (13), taking care not to “cut” o-ring energizer/seal (27.4). Using thumbs, work the o-ring energizer/seal (27.4) up and into the groove of the piston-guide bearing (13). **NOTE:** *A very slight amount of fluid and elastomer compatible lubricant is recommended as an installation aid.*
2. Place wiper washer (17.1) into “cup” of Wiper Seal (16). Holding these parts (17.1 & 16) between thumb and forefinger, insert into cage (19) at an approximate 45° angled approach with wiper washer (17.1) on bottom, wiper seal (16) on top with turned-down lip of wiper seal (16) entering cage (19) first. Rotate wiper seal (16) and wiper washer (17.1) to a level position approximately half way down into cage (19). Allow wiper washer (17.1) to rest on bottom of cage (19).
3. Position TFE cap seal (27.1) ring with rectangular cross-section at end of piston-guide bearing (13). Stretch cap seal (27.1) over lower end of piston-guide bearing (13) using thumbs to work the cap seal (27.1) onto the piston-guide bearing (13). **DO NOT USE A TOOL FOR THIS STEP.** Continue pressing cap seal (27.1) upwards towards the groove until the cap seal (27.1) “snaps” into the groove of the piston-guide bearing (13).
4. Position piston-guide bearing (13) over and into upper end of cage (19) until the cap seal (27.1) edge touches the upper lip of the cage (19). While gently applying force to press the piston-guide bushing (13) into the cage (19), simultaneously use fingers to lightly press the cap seal (27.1) inwards into the groove of the piston-guide bearing (13) until the cap seal (27.1) “slips into” the cage (19). **DO NOT USE TOOLS, LUBRICANT, OR HEAVY FORCE TO ENGAGE THE CAP SEAL (27.1) INTO THE CAGE (19).** Do not press inwards on the Cap Seal (27.1) too much or the cap seal (27.1) may slide out of its groove or the cap seal (27.1) can be damaged.

d. Type PR:

1. Stretch corrugated metal piston ring energizer (27.6) over lower circumference of piston-guide bearing (13). Using thumbs work the energizer (27.6) into the piston-guide bearing (13) groove.
2. Spread a piston ring seal (27.5) and slide over lower circumference of piston-guide bearing (13), taking care not to “cut” piston ring seal (27.5). Using thumbs, work the piston ring seal (27.5) into the groove of the piston-guide bearing (13). Repeat this procedure with a second piston ring seal (27.5). **NOTE:** *A piston ring assembly (PRA) consists of one metal corrugated energizer (27.6) and two piston ring seals (27.5).*
3. Position piston-guide bearing (13) over and into upper end of cage (19) until the lower piston ring seal (27.5) touches the upper lip of the cage (19). While gently applying force to press the piston-guide bearing (13) into the cage (19), simultaneously use fingers to lightly circumferentially press the first (lower) piston ring seal (27.5) inwards into the piston-guide bearing (13) groove until the first piston ring seal (27.5) “slips into” the cage (19). Repeat for the second piston ring seal (27.5).

e. Type PW:

1. Place wiper washer (17.1) into “cup” of Wiper Seal (16). Holding these parts (17.1 & 16) between thumb and forefinger, insert into cage (19) at an approximate 45° angled approach with wiper washer (17.1) on bottom, wiper seal (16) on top with turned-down lip of wiper seal (16) entering cage (19) first. Rotate wiper seal (16) and wiper washer (17.1) to a level position approximately half way down into cage (19). Allow wiper washer (17.1) to rest on bottom of cage (19).
2. Stretch corrugated metal piston ring energizer (27.6) over lower circumference of piston-guide bearing (13). Using thumbs work the energizer (27.6) into the piston-guide bearing (13) groove.
3. Spread a piston ring seal (27.5) and slide over lower circumference of piston-guide bearing (13), taking care not to “cut” piston ring seal (27.5).

Using thumbs, work the piston ring seal (27.5) into the groove of the piston-guide bearing (13). Repeat this procedure with a second piston ring seal (27.5). **NOTE:** A piston ring assembly (PRA) consists of one metal corrugated energizer (27.6) and two piston ring seals (27.5).

4. Position piston-guide bearing (13) over and into upper end of cage (19) until the lower piston ring seal (27.5) touches the upper lip of the cage (19). While gently applying force to press the piston-guide bearing (13) into the cage (19), simultaneously use fingers to lightly circumferentially press the first (lower) piston ring seal (27.5) inwards into the piston-guide bearing (13) groove until the first piston ring seal (27.5) “slips into” the cage (19). Repeat for the second piston ring seal (27.5).
- f. Type UC:
 1. Stretch u-cup seal (27.3) over lower circumference of piston-guide bearing (13), taking care not to “cut” u-cup seal (27.3) on the protruding shelf that is part of the piston-guide bearing’s (13) groove. Ensure that the u-cup seal (27.3) is oriented with the center-open-downwards as shown in Figure 1, as the u-cup seal (27.3) depends upon the P1-Inlet Pressure to pressure activate the seal for proper sealing action.
 2. Position piston-guide bearing (13) over and into upper end of cage (19) until the cap seal (27.1) edge touches the upper lip of the cage (19). While gently applying force to press the piston-guide bearing (13) into the cage (19), simultaneously use fingers to lightly press the u-cup seal (27.3) inwards into the groove of the piston-guide bearing (13) until the u-cup seal (27.3) “slips into” the cage (19). DO NOT USE TOOLS, LUBRICANT, OR HEAVY FORCE TO ENGAGE THE U-CUP SEAL (27.3) INTO THE CAGE (19).
4. Place properly oriented seat ring (21) onto its shoulder at the lower end of cage (19).
5. Composition Diaphragm Designs:
 - a. Place new o-ring lower stem seal (14.3) into groove of valve plug (20).

- b. Insert valve plug (20) upwards through lower end of cage (19) and through the center hole in piston-guide bearing (13), also capturing the camber adjusting washer (17.2) or wiper washer (17.1) and wiper seal (16), if supplied. Hold plug (20) and cage (19) together.
- c. Place an oversized nut or stack of washers, the same approximate height of the upper diaphragm pressure plate (8) and the lower diaphragm pusher plate (10), over the upper end of valve plug (20) and temporarily secure with diaphragm lock nut (7), manually tightened. Do **NOT** allow valve plug (20) to rotate against seat ring (21) during tightening.
- d. This completes ITA preliminary/partial reassembly.

6. Metal Diaphragm Designs:

- a. Insert valve plug (20) upwards through lower end of cage (19) and through the center hole of camber adjusting washer (17.2) or wiper washer (17.1) and wiper seal (16).
- b. Engage valve plug (20) with piston-guide bearing (13) threads and tighten manually as far as possible.
- c. Place ITA into a vise with leaded jaws and grasp at a hub location on the valve plug (20) that is not in the “spindle” zone. (See Figure 3.)
- d. Using a special double-posted spanner wrench fitting (to order see NOTE in Section X, Parts Ordering Information), tighten piston-guide bearing (13) to the valve plug (20) with the following torque values. Do **NOT** allow valve plug (20) to rotate against seat ring (21) during tightening.
- e. This completes ITA reassembly.

F. **Main Reassembly:**

1. Place body (23) in a vise.
2. Reinstall internal sensing drilled plug (32) with compatible thread sealant.
3. Insert the lower piston spring (22) into the body (23), if supplied.
4. Fit the o-ring cage seal (15) into its body (23) groove.
5. With the ITA held manually in the closed position, insert ITA into body (23).
6. Properly align all three cage bolt (18) holes as there is only one circumferential location

possible for this alignment. If a lower piston spring (22) is used, apply downward force to the top of the cage (19) until the ITA is lowered sufficiently to engage the cage bolts (18) into the body (23). Engage all of the cage bolts (18), then evenly screw in the cage bolts in one-half revolution increments to pull down the ITA evenly, taking care NOT TO “ANGLE” the ITA in the BODY. Torque the cage bolts (18) to 13-15 ft-lbs (17.6-20.3 N-m).

7. **Composition Diaphragm Designs:**

- a. For the following steps b.– h., the upper end of valve plug (20) **MUST** be manually held up if unit is not supplied with lower piston spring (22).
- b. Remove temporarily installed diaphragm lock nut (7) and spacers of previous Step 5.c. this section.
- c. Place new o-ring middle stem seal (14.2) into groove of piston-guide bearing (13) upper surface.
- d. Position lower diaphragm pusher plate (10) over upper end of valve plug (20) with tongue and groove “groove” on upper side.
- e. Place new o-ring upper stem seal (14.1) over upper end of valve plug (20).
- f. Place diaphragm(s) (9) over end of valve plug (20). **NOTE:** For multiple diaphragms (9) that include TFE material, the TFE should be on wetted side; for 3-ply TFE elastomer diaphragm (9), stackup is TFE-HK-TFE, beginning with lower wetted diaphragm (9) first.
- g. Place upper diaphragm pressure plate (8) over upper end of valve plug (20) with tongue and groove “ridge” on lower side.
- h. Place lubricant on valve plug (20) threaded end. Engage diaphragm lock nut (7) with upper end of valve stem (20) as far as possible manually.
- i. Place a wrench on diaphragm lock nut (7) and a torque wrench on the upper end of valve plug (20). Hold torque wrench stationary and rotate diaphragm lock nut (7) to the following torque values:

| Body Size in (DN) | Torque Value Ft-lbs (N-m) |
|------------------------|------------------------------|
| 1/2" - 1" (15 - 25) | 60 - 70 (81 - 95) |
| 1 1/4" - 2" (32 - 50) | 120 - 130 (163 - 176) |
| 2 1/2" - 4" (65 - 100) | 180 - 200 (244 - 271) |

DO NOT allow valve plug (20) to rotate against seat ring (21) during tightening.

- j. This completes ITA reassembly.

8. **Metal Diaphragm Designs:**

- a. Install new diaphragm gasket (37) onto body (23) diaphragm flange.
- b. Position diaphragm(s) (9) onto body's (23) diaphragm flange with bolt holes aligned.
- c. Position upper diaphragm pressure plate (8) onto center top of diaphragm(s) (9) with rounded side of plate (8) on bottom next to diaphragm (9).

9. Aligning matchmarks and bolt holes, place cover dome (25) onto body (23).

10. Reinstall all flange bolts (11) and nuts (12) with nameplate (99) located under one bolt head. Hand-tighten nuts (12).

NOTE: If a 3-ply diaphragm is being used, it is important that the diaphragm (9) is “pre-formed” – pulled together to remove as much entrapped air as possible and allow formation of a diaphragm (9) convolution. Starting with the body bolts and nuts (11,12) hand tightened, “preforming” can be accomplished by any one of the following techniques:

- a. Apply 30 psig (2.1 Barg) pressure to the valve outlet. OR
Block the valve outlet and apply 30 psig (2.1 Barg) under the diaphragm through the 1/4" (DN8) NPT (plugged) external pressure sensing connection on the valve diaphragm flange.
 - b. Leave pressure on through tightening of bolting (11,12).
11. Evenly tighten the body bolting (11,12) in an alternating cross pattern in one revolution increments to the following torque values:

| Body Size in (Dn) | Torque Value Ft-lbs (N-m) |
|-----------------------|------------------------------|
| 1/2" - 1" (15 - 25) | 60 - 70 (81 - 95) |
| 1 1/4" - 2" (32 - 50) | 120 - 130 (163 - 176) |

If supplied, remove pressure of previous Step 10.

G. **Units with Supported Diaphragm Designs:**

1. A supported diaphragm (9) construction is designated as Opt-81 High Outlet Pressure. Both upwards and downwards directions are protected against pressure reversal; i.e. pressure on one side of diaphragm (9) with no pressure on other side of diaphragm (9).
2. **Body Sizes 2" (DN50) and Smaller; Composition Diaphragm.** (See Figure 5.)
 - a. Body (23) is specially machined with a shelf to capture a lower diaphragm support ring (35).

- b. Cover dome (25) is specially machined to provide a surface for the upper diaphragm (9) support. Lower diaphragm support ring (35) is captured by its location. Upon removal of cover dome (25) and diaphragm (9), the lower diaphragm support ring (35) can be lifted upwards and out of the body (23) cavity.
- c. Reinstallation is a reversal of Step b. above.

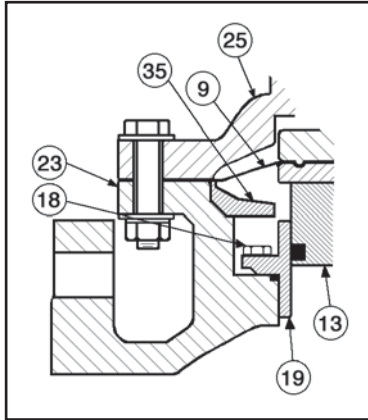

Figure 5: Opt-81 — Composition Diaphragm Construction, 2" (DN50) and Smaller

H. Converting Internal/External Sensing:

1. Disassemble the regulator and remove the diaphragm(s) (9) according to Steps 1-12 in Part B – Main Regulator Disassembly.
2. To convert from internal to external sensing, remove the drilled pipe plug (32) and install a solid pipe plug. Reverse this step for converting from external to internal sensing.
3. Reassemble the regulator according to Part F – Main Regulator Reassembly.

I. Pressure Testing:

1. If a hydrostatic pressure test is performed, pressure must be applied to all three of cover dome (25), inlet and outlet of body at the same level.
DO NOT HYDROSTATICALLY TEST WITHOUT COVER DOME PRESSURIZED. NOT ADHERING WILL DO PHYSICAL DAMAGE TO INTERNALS THAT COULD RENDER THE UNIT INOPERABLE.
2. Inboard Leakage Test.
 - a. Release all loading pressure in cover dome.
 - b. Pressurize inlet to 30 psig (2.1 Barg) with air, GN₂.
 - c. Tube outlet to a beaker of water to observe number of escaping gas bubbles.

Inboard leakage path may be via plug/seat or dynamic side seal.

3. Pressure Containment Test.
 - a. Pressurize inlet to 200 psig (13.8 Barg) and outlet and cover dome to 150 psig (10.3 Barg) with air or GN₂.
 - b. Spray liquid lead detector and check all external leak points; i.e. plugged connections, diaphragm flange and diaphragm bolting.
4. Excessive leakage will require disassembly, examination of sealing elements, correction of problem, reassembly and retesting.

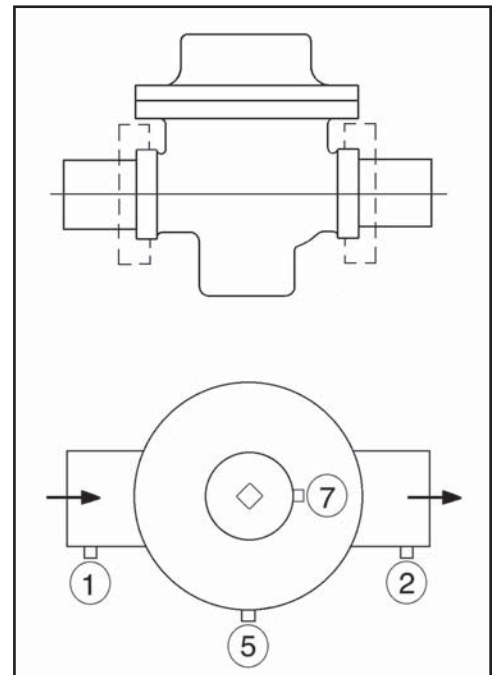

Figure 6: Location of Auxiliary Ports

SECTION VIII

VIII. PRESSURE LOADING

1. Loading pressure can be supplied using various schemes. Please reference DA4/P-LOAD-TB for the schematics of these various schemes, including:
 - pressure unloading using BPV
 - pressure loading using PRV
 - pressure loading using pilot
 - pressure loading using I/P transducer
2. The Model DA4 exhibits a deviation in outlet controlled pressure when the inlet pressure varies; this “effect” is identified as ISR – Inverse Sympathetic Ratio. Its relative pressure effect can be calculated from the following equation.

LOADING PRESSURE FOR MODEL DA4 APPLIED PRESSURES

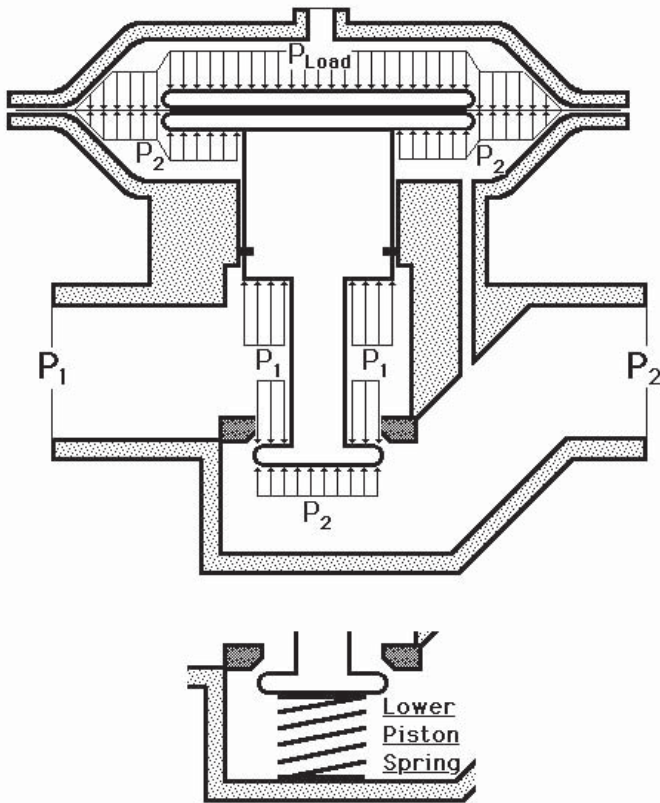

| ISR FACTOR | |
|---------------------------|---------|
| BODY SIZE in (DN) | ISR - % |
| 1/2" - 1" (15 - 25) | 3.0 |
| 1 1/4" - 1 1/2" (32 - 40) | 4.0 |
| 2" (50) | 2.0 |
| 2 1/2" - 4" (65 - 100) | 5.4 |

| PISTON SPRING | | |
|---|--|------------------------|
| LOWER PISTON SPRING RANGE psig (Barg) | ΔP Piston Spring psig (Barg) | LVPS psig (Barg) |
| none (none) | 0 (0) | 0 (0) |
| 2 - 5 (.14 - .34) | 3 (.21) | 2 (.14) |
| 1 - 2 (.07 - .14) | 1 (.07) | 1 (.07) |
| 4 - 10 (.28 - 6.9) | 6 (.41) | 4 (.28) |

| Body Size in (DN) | SIZE / ORIENTATION - S/O Factor | |
|---------------------------|---------------------------------|-------------------------|
| | Cover Dome on Top | Cover Dome on Bottom |
| 1/2" - 1" (15 - 25) | 1 | -1 |
| 1 1/4" - 1 1/2" (32 - 40) | 2 | -2 |
| 2" (50) | 2.5 | -2.5 |
| 2 1/2" - 3" (65 - 80) | 3 | -3 |
| 4" (100) | 4 | -4 |

$$P_{LOAD} = \text{ISR Effect} + \text{Lower Piston Spring Compression Effect} + \text{Lower Piston Spring Spring Preload} + \text{Body Size Orientation Effect}$$

$$P_{Load} = P_2 + [\text{ISR} \times (P_1 - P_2)] + \left[\frac{C_{V,Req'd}}{C_{V,Max}} \times \Delta P_{Piston Spr.} \right] + LVPS + S/O_{Factor}$$

Figure 8: Loading Pressure Formula

SECTION IX

IX. TROUBLE SHOOTING GUIDE

When trouble shooting this regulator there are many possibilities as to what may be causing problems. Many times, the regulator itself is not defective, but one or more of the accessories may be. Sometimes the process may be causing difficulties.

The key to efficient trouble shooting is information and communication. The customer should try to be as precise as possible in their explanation of the problem, as well as their understanding of the application and operating conditions.

It is imperative the following information be provided by the customer:

- Fluid (with fluid properties)
- Range of outlet pressure
- Range of flow rate
- Range of fluid temperature
- Range of inlet pressure
- Range of ambient temperature

Pressure readings should be taken at every location where pressure plays a role - i.e., regulator inlet (as close as possible to inlet port), regulator outlet (as close as possible to outlet port), etc.

Following are some of the more common complaints along with possible causes and remedies.

| 1. Erratic regulation, instability or hunting. | |
|--|---|
| Possible Causes | Remedies |
| A. Sticking of internal parts. | A. Remove internals, clean, and if necessary, replace. |
| B. Load changes are too quick for system. | B. Convert to external sensing (if necessary) and install an orifice or needle valve in external sensing line. |
| C. Oversized regulator. | C. Check actual flow conditions; resize regulator for minimum and maximum flow; if necessary, replace with smaller regulator. |
| D. Too much variation in Inlet Pressure - P1. | D. Consider use of a pilot for closer Outlet Pressure – P2 |
| 2. Erratic regulation, instability or hunting (liquid service). | |
| Possible Causes | Remedies |
| A. Air trapped under diaphragm. | A. Install valve on external sensing port and bleed off air. (Install regulator upside down to help prevent reoccurrence. |
| 3. Downstream pressure will not reach desired setting. | |
| Possible Causes | Remedies |
| A. Supply pressure is down (confirm on pressure gauge). | A. Increase supply pressure. |
| B. Undersized regulator. | B. Check actual flow conditions; resize regulator for minimum and maximum flow; if necessary, replace with larger regulator. |
| C. Pressure loading system pressure restricted. | C1. Clean restriction or bleed orifices. C2. Clean filter(s). C3. Clean loading pressure control device. |
| D. Faulty loading pressure control device. | D. Replace/repair loading pressure control device. |
| 4. Diaphragm continually breaks (steam service regulators). | |
| Possible Causes | Remedies |
| A. Stem seals (14) which protect fluorocarbon elastomer in diaphragm assembly may have deteriorated. | A. Replace with new stem seals (14). |
| B. Diaphragm nut (7) may not be torqued to correct value. | B. Confirm torque value in accordance with Section VII, F-7-i. |
| C. Diaphragm too stiff causing it to crack. | C. Follow proper preforming and air evacuation techniques during diaphragm installation in accordance with Section VII, F-10. |

| | |
|---|---|
| 5. Diaphragm continually breaks (all regulators). | |
| Possible Causes | Remedies |
| A. Differential pressure across diaphragm may have exceeded limits. (See Table 1 in DA4-TB) | A1. Be aware of limits as well as where the various pressures are acting. Install pressure safety equipment as necessary. A2. Consider if full diaphragm support, Opt-81, should be added. |
| 6. Leakage at diaphragm flange. | |
| Possible Causes | Remedies |
| A. Body bolts not torqued properly. | A. Torque to proper value (see Section VII, F-11). |
| B. Pressures at diaphragm may be too high. | B. Consult factory. |
| 7. Leakage across seat. | |
| Possible Causes | Remedies |
| A. Contamination (debris) in regulator. | A. Remove internals, clean, and if necessary, replace sealing and seating elements. * |
| B. Oversized regulator; valve plug operates directly next to seat. | B. Check actual flow conditions; resize regulator for minimum and maximum flow; if necessary, replace with smaller regulator. |
| * Seat leakage may be diagnosed when a failure of the dynamic side seal has occurred. Inspect both potential internal leak paths. | |

SECTION X

X. ORDERING INFORMATION:

NEW REPLACEMENT UNIT vs PARTS "KIT" FOR FIELD REPAIR

To obtain a quotation or place an order, please retrieve the Serial Number and Product Code that was stamped on the metal name plate and attached to the unit. This information can also be found on the Bill of Material (parts list) that was provided when unit was originally shipped.) (Serial Number typically 6 digits). Product Code typical format as follows: (last digit is alpha character that reflects revision level for the product).

□□□□ - □□□□ 7 - □□□□□□□□□□

PARTS "KIT" for FIELD REPAIR:

Contact your local Cashco, Inc., Sales Representative with the Serial Number and Product code. Identify the parts and the quantity required to repair the unit from the Bill of Materials sheet that was provided when unit was originally shipped.

NOTE: Those part numbers that have a quantity indicated under "Spare Parts" in column "A" reflect minimum parts required for inspection and rebuild, - "Soft Goods Kit". Those in column "B" include minimum trim replacement parts needed plus those "Soft Goods" parts from column "A".

If the "BOM" is not available, refer to the cross-sectional drawings included in this manual for part identification and selection.

Local Sales Representative will provide quotation for appropriate Kit Number, Price and Availability.

NEW REPLACEMENT UNIT:

Contact your local Cashco, Inc., Sales Representative with the Serial Number and Product code. With this information they can provide a quotation for a new unit including a complete description, price and availability.

CAUTION

Do not attempt to alter the original construction of any unit without assistance and approval from the factory. All purposed changes will require a new name plate with appropriate ratings and new product code to accomodate the recommended part(s) changes.

NOTE: In addition to ordering repair parts, it is recommended that a special double-posted spanner wrench fitting be ordered for use in the maintenance of the ITA. See table on page 15 for part number.

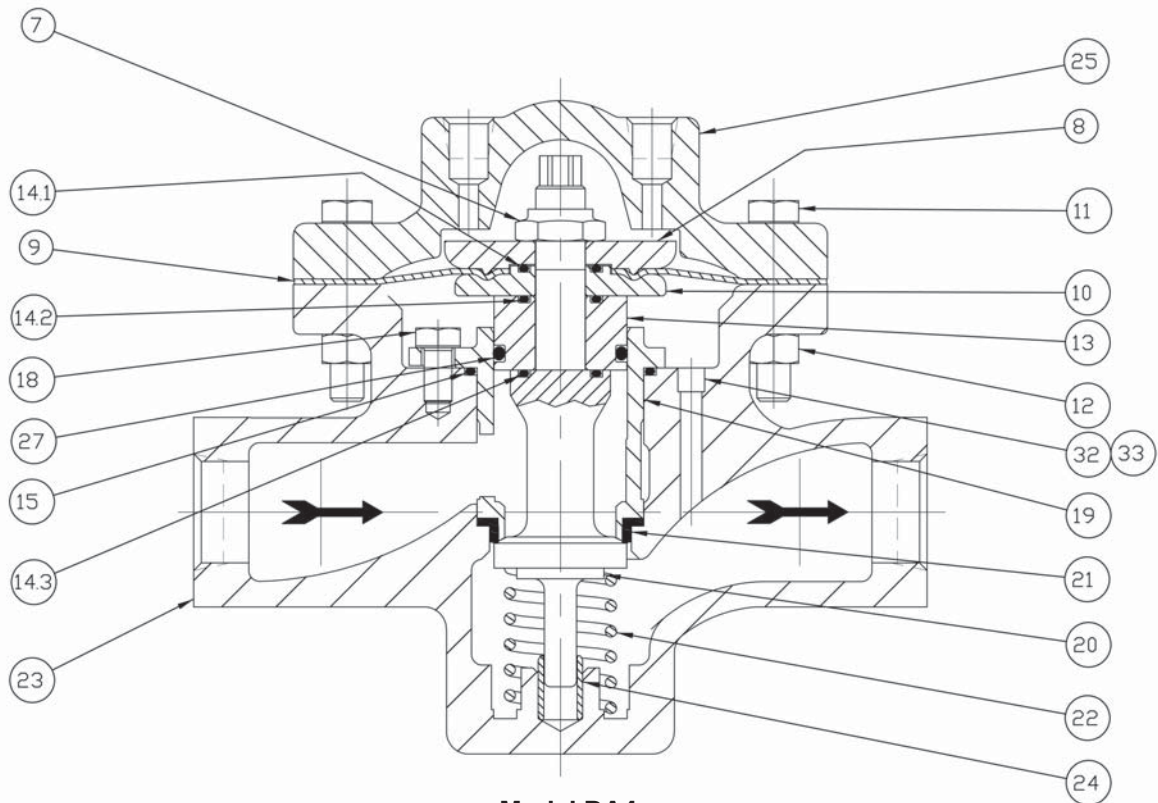

**Model DA4
Composition Diaphragm
(without Wiper Seal)**

| Item No. | Description | Item No. | Description |
|-----------------|--------------------------------|-----------------|--|
| 7 | Diaphragm Lock Nut | 21* | Seat Ring |
| 8 | Upper Diaphragm Pressure Plate | 22 | Lower Piston Spring (if supplied) |
| 9* | Diaphragm | 23 | Body |
| 10 | Lower Diaphragm Pusher Plate | 24 | Lower Guide Bushing |
| 11 | Flange Bolts | 25 | Cover Dome |
| 12 | Flange Bolt Nuts | 26 | Tap Plug (Not Shown) |
| 13 | Piston-Guide Bearing | 27* | Dynamic Side Seal (see Figure 1) |
| 14* | Stem Seals | 32 | Internal Sensing Plug – Drilled (Internal Sensing Only) |
| 14.1 | Upper Stem Seal | 33 | Internal Sensing Plug – Solid (External Sensing Only) |
| 14.2 | Middle Stem Seal | | |
| 14.3 | Lower Stem Seal | 99 | Nameplate |
| 15* | Cage Seal | | |
| 18 | Cage Cap Screws | | |
| 19 | Cage | | |
| 20 | Valve Plug | | |

* Recommended Repair Parts.

| Double-Posted Spanner Wrench Fitting | |
|---|--------------------|
| Body Size | Part Number |
| 1/2", 3/4", 1" (DN15, 20, 25) | 112-A4-6-P0459-00 |
| 1 1/4", 1 1/2", 2" (DN32, 40, 50) | 112-A4-6-P0459-01 |

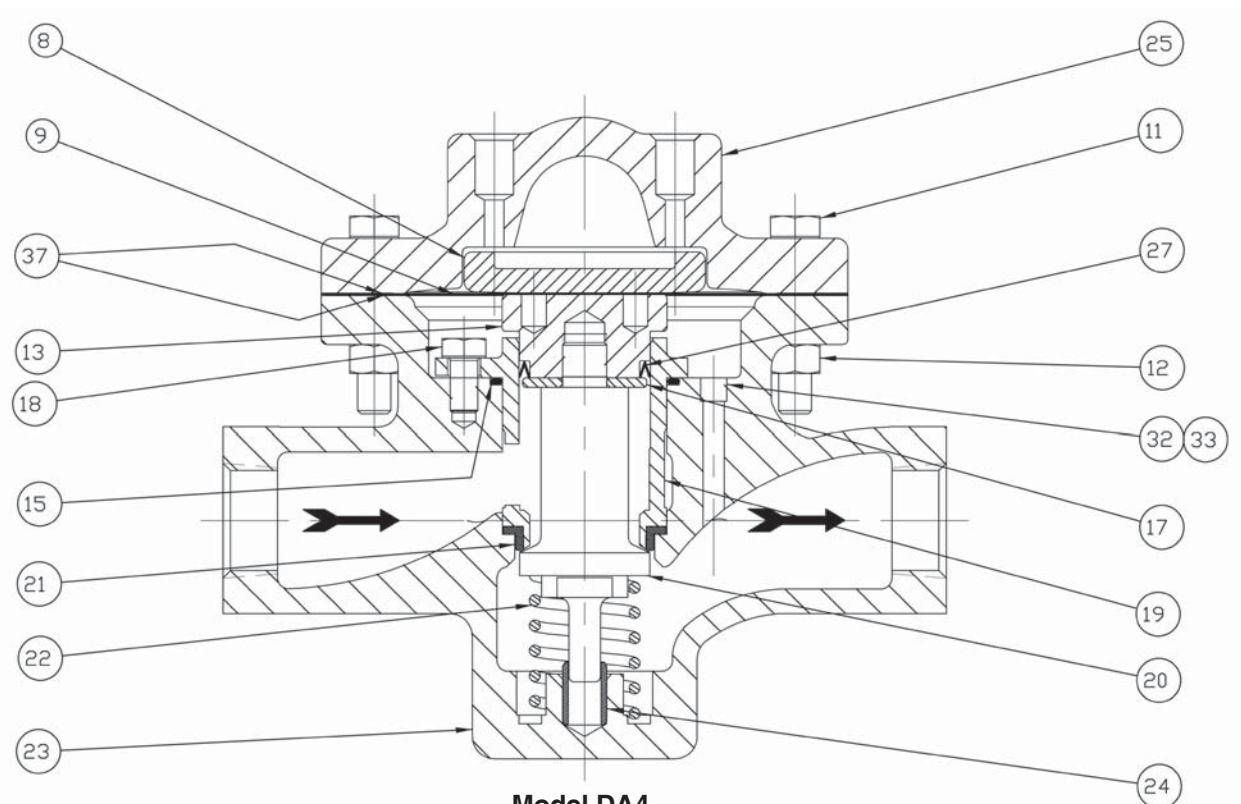

**Model DA4
Metal Diaphragm
(with Type UC – U-Cup Dynamic Seal)**

| Item No. | Description | Item No. | Description |
|-----------------|--------------------------------|-----------------|--|
| 8 | Upper Diaphragm Pressure Plate | 23 | Body |
| 9* | Diaphragm | 24 | Lower Guide Bushing |
| 11 | Flange Bolts | 25 | Cover Dome |
| 12 | Flange Bolt Nuts | 26 | Tap Plug (Not Shown) |
| 13 | Piston-Guide Bearing | 27* | Dynamic Side Seal (See Figure 1) |
| 15* | Cage Seal | 32 | Internal Sensing Plug – Drilled (Internal Sensing Only) |
| 17 | Camber Adjusting Washer | 33 | Internal Sensing Plug – Solid (External Sensing Only) |
| 18 | Cage Cap Screws | 37* | Diaphragm Gasket |
| 19 | Cage | 99 | Nameplate |
| 20 | Valve Plug | | |
| 21* | Seat Ring | | |
| 22 | Lower Piston Spring | | |

* Recommended Repair Parts

Cashco, Inc.
P.O. Box 6
Ellsworth, KS 67439-0006
PH (785) 472-4461
Fax (785) 472-3539
www.cashco.com
E-mail: sales@cashco.com
 exportsales@cashco.com
Printed in USA IOM-DA3/4