



MODEL 1000HP - BASIC PRESSURE REDUCING REGULATOR

SECTION I

I. DESCRIPTION AND SCOPE:

The Model 1000HP is a pressure reducing regulator used to control downstream (outlet or P_2) pressure to levels between 10 and 300 psig (0.7-20.6 Barg). Sizes are 1/2", 3/4", 1", 1-1/4", 1-1/2" and 2" (DN15, 20, 25, 32, 40 and 50).

The unit is designed for liquid, gaseous or steam service with proper trim utilization, and proper jet selection. Refer to Technical Bulletin 1000HP-TB for sizing, application and selection recommendations.

Installation, operation and maintenance manuals (IOM's) also exist for the following other Model 1000 products:

1000LP-Basic

1000HP-Differential

1000HP-Cryogenic

SECTION II



CAUTION

For welded installations, all internal trim parts, seals and diaphragm(s) must be removed from regulator body prior to welding into pipeline. The heat of fusion welding will damage non-metallic parts if not removed. **NOTE: This does not apply to units equipped with extended pipe nipples.**



CAUTION

Installation of adequate overpressure protection is recommended to protect the regulator from overpressure and all downstream equipment from damage in the event of regulator failure.

II. INSTALLATION:

1. An inlet block valve should always be installed. An outlet block valve is recommended.
2. If service application is continuous such that shutdown is not readily accomplished, it is recommended that an inlet block valve and a manual bypass valve be installed.
3. Pipe unions must be installed to allow removal from piping. Trim can only be changed by unit removal from pipeline. If flanges are utilized, a lap joint flange is required on the inlet end of the regulator to help align bolt holes as the cylinder screws into place.
4. An outlet pressure gauge should be located approximately ten pipe diameters downstream, and within sight.
5. All installations should include a downstream relief device if the inlet pressure could exceed the pressure rating of any downstream equipment or the maximum outlet pressure rating of the unit.

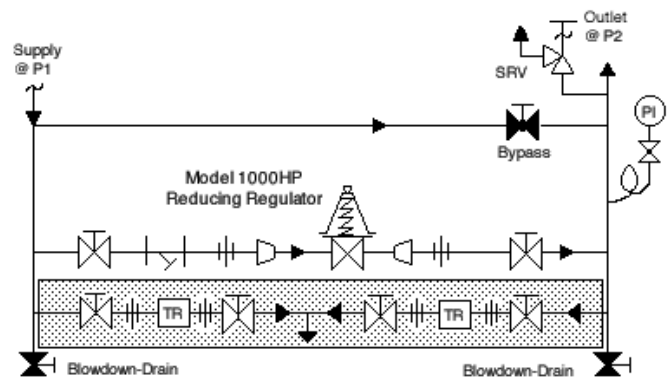

(Shaded portion for steam/condensate systems)
Recommended Piping Schematic
For Pressure Reducing Station



CAUTION

The maximum outlet pressure listed on the nameplate is the "upper operative limit" for the sensing diaphragm. Higher pressures could damage the diaphragm. (Field hydrostatic tests frequently destroy diaphragms. **DO NOT HYDROSTATIC TEST THRU AN INSTALLED UNIT; ISOLATE FROM TEST.**)

6. Clean the piping of all foreign material including chips, welding scale, oil, grease and dirt before installing the regulator. Strainers are recommended.

7. In placing thread sealant on pipe ends prior to engagement, ensure that excess material is removed and not allowed to enter the regulator upon startup.
8. Flow Direction: Install so the flow direction matches the arrow cast on the body.
9. For best performance, install in well drained horizontal pipe, properly trapped if a steam service application.
10. Basic regulator may be rotated around the pipe axis 360°, and may be installed in a horizontal or

vertical pipeline. Recommended position is with spring chamber vertical upwards. Orient to prevent the spring chamber vent hole from collecting rainwater or debris.

11. Regulators are not to be direct buried underground.
12. For insulated piping systems, recommendation is to not insulate regulator.
13. Cashco does not recommend field welding on the cylinder (inlet) end of the body due to the possibility of warpage.

SECTION III

III. PRINCIPLE OF OPERATION :

1. The Model 1000 is available in two variations: 1000LP (larger diaphragm) for downstream pressure control from 1-30 psig (0.07-2.06 Barg); 1000HP (smaller diaphragm) for downstream pressure control from 10-300 psig (0.7-20.6 Barg), body size dependent.
2. Movement occurs as pressure variations register on the diaphragm. The registering pressure is the outlet, P_2 , or downstream pressure. The range spring opposes diaphragm movement. As outlet pressure drops, the range spring pushes the diaphragm down, opening the port; as outlet pressure increases, the diaphragm pushes up and the port closes.
3. The Model 1000 includes a rocker arm in its operational mechanism. The rocker arm allows the regulator to operate flow-to-open (FTO), rather than conventional flow-to-close (FTC), which increases rangeability.
4. Due to the FTO design, there is a limit as to how low of a downstream (P_2 or outlet) pressure level

setting is capable for a given inlet P_1 pressure. This is a function of the ratio of the port area to diaphragm area. It is possible for there to be too high of an inlet pressure for the regulator to close off against. (Refer to 1000-TB, Tables 9 through 12 for limits.) Reduced ports, Option 1000-12, allow lower downstream (P_2 or outlet) pressure settings for a given upstream (P_1 or inlet) pressure level.

5. The FTO design also is limited by a minimum pressure drop. If the pressure drop is below 5 psid, an Option 1000-17 piston spring should be utilized to assist opening the piston.
6. The Model 1000 includes an aspiration jet effect, due to the clearance of the piston from the body near the outlet. These clearances vary as to whether the fluid is a gas (including steam), a liquid, or a viscous liquid (requires Option 1000-27). Jets must be selected to match one of these three general fluids. An improper jet selection will reduce performance.
7. A complete diaphragm failure will cause the regulator to fail open.

SECTION IV

IV. STARTUP:

1. Start with the block valves closed. A bypass valve may be used to maintain outlet pressure in the downstream system without changing the following steps.
2. Relax the range spring by turning the adjusting screw counterclockwise (CCW) a minimum of three (3) full revolutions. This reduces the outlet (downstream) pressure set point.

3. If it is a "hot" piping system, and equipped with a bypass valve, slowly open the bypass valve to pre-heat the system piping and to allow slow expansion of the piping. Ensure proper steam trap operation if installed. Closely monitor outlet (downstream) pressure via gauge to ensure not over-pressurizing. **NOTE:** *If no bypass valve is installed, extra caution should be used in starting up a cold system; i.e. do everything slowly.*

4. Crack open the outlet (downstream) block valve.
5. Slowly open the inlet (upstream) block valve observing the outlet (downstream) pressure gauge. Determine if the regulator is flowing. If not, slowly rotate the regulator adjusting screw clockwise (CW) until flow begins.
6. Continue to slowly open the inlet (upstream) block valve until fully open.
7. Continue to slowly open the outlet (downstream) block valve, especially when the downstream piping system isn't pressurized. If the outlet (downstream) pressure exceeds the desired pressure, close the block valve and go to Step 2, then return to Step 4.
8. When flow is established steady enough that the outlet (downstream) block valve is fully open, begin to slowly close the bypass valve if installed.
9. Develop system flow to a level near its expected normal rate, and reset the regulator set point by turning the adjusting screw CW to increase outlet pressure, or CCW to reduce outlet pressure.
10. Reduce system flow to a minimum level and observe set point. Outlet pressure will rise from the set point of Step 9. The maximum rise in outlet pressure on decreasing flow should not exceed the stated upper limit of the range spring by greater than 30%; i.e. 10–40 psig (0.7-2.75 Barg) range spring, at low flow the outlet pressure should not exceed 52 psig (3.6 Barg). If it does, consult factory.

SECTION V

V. SHUTDOWN:

1. On systems with a bypass valve, and where system pressure is to be maintained as the regulator is shut down, slowly open the bypass valve while closing the inlet (upstream) block valve. Fully close the inlet (upstream) block valve. (When on bypass, the system pressure must be constantly observed and manually regulated.) Close the outlet (downstream) block valve.

	CAUTION
Do not walk away and leave a bypassed regulator unattended.	

2. If the regulator and system are to both be shut-down, slowly close the inlet (upstream) block valve. Close the outlet (downstream) valve only if regulator removal is required.

SECTION VI

VI. MAINTENANCE:

	WARNING
SYSTEM UNDER PRESSURE. Prior to performing any maintenance, isolate the regulator from the system and relieve all pressure. Failure to do so could result in personal injury.	

A. General:

1. Maintenance procedures hereinafter are based upon removal of the unit from the pipeline where installed.
2. Owner should refer to owner's procedures for removal, handling and cleaning of reusable parts, and disposal of nonreusable parts, i.e. gaskets, suitable solvents, etc.
3. If desired, the gaskets may be lubricated with a light oil provided it is compatible with the fluid.

4. Regulators originally supplied as "oxygen cleaned" (Options 1000-55) are assembled using special gasket sealant, Fluorolube GR-362¹, or equivalent. Cashco, Inc. recommends following factory cleaning specification #S-1134, or equivalent. Contact factory for details.

B. Diaphragm Replacement:

1. Securely install the body (1) in a vise with the spring chamber (2) directed upwards.

	WARNING
SYSTEM UNDER COMPRESSION. Prior to removing flange bolts, relieve spring compression by backing out the adjusting screw. Failure to do so may result in flying parts that could cause personal injury.	

2. Remove closing cap (31) if provided. Relax range spring (27) by turning adjusting screw (6) CCW until removed from spring chamber (2).

¹ Product of Fisher Scientific Company

3. Paint or embed a match mark between body casting (1) and spring chamber casting (2) along flanged area.
4. Remove all diaphragm nuts (9) and bolts (8). Remove nameplate (28).
5. Remove spring chamber (2), range spring (27) and spring button (4).

NOTE: The text hereafter will refer to “pusher plate and stud” (13) as a single part, for 1/2” – 1-1/4” sizes (DN15-DN32), and as two separate parts, the “pusher plate (5)” and a “pusher plate stud” (13) for sizes 1-1/2” and 2” (DN40 & DN50).

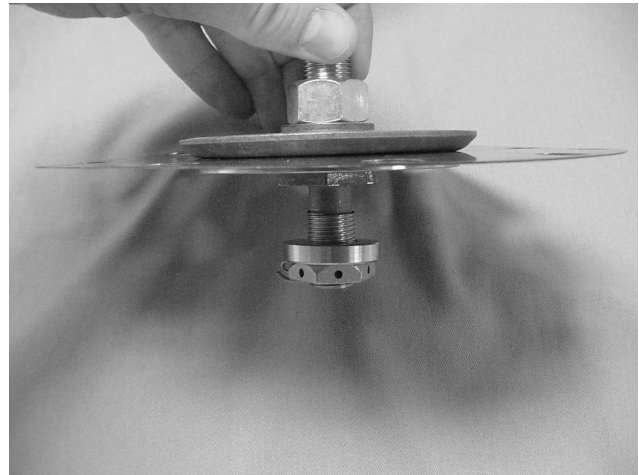

6. Pry up the diaphragm(s) (20) and diaphragm gasket (19) around the perimeter of the body (1) diaphragm flange to ensure that the diaphragm(s) (20) are not “sticking”. (Diaphragm gasket (19) is not used with a composition (soft) diaphragm.)
7. Remove the diaphragm sub-assembly by sliding the pusher plate and stud (13) and nut (11) in the direction of the regulator’s inlet, approximately 1/2”-3/4” (12-20 mm). The pusher plate and stud (13), stud nut (10), and stud collar (16) should disengage with the rocker arm (14) slot. Lift vertically for the diaphragm sub-assembly removal.
8. Place the pusher plate stud (13) in a separate vise, gripping the stud (13) on the hexagonal cast-in-place edges located on the underneath side of the pusher plate stud. **NOTE:** Do not remove the stud nut (10), stud collar (16) and the location locking cotter pin (15). Loosen and remove nut (11).
9. Remove pressure plate (3) by lifting.
10. Pry loose pusher plate and stud (13) from diaphragm(s) (20) or from pusher plate gasket (12). (Pusher plate gasket (12) is not used with a composition (soft) diaphragm.) Remove the diaphragm(s) (20).
11. Remove pusher plate gasket (12) from pusher plate and stud (13).
12. Clean gasket sealing surface of pusher plate and stud (13) thoroughly.
13. Install new pusher plate gasket (12), if required, over pusher plate and stud (13).

Diaphragm sub-assembly consists of items (10), (11), (12), (13), (15), (16) and (20). (Metal diaphragm design).

14. Install new diaphragm(s) (20) over pusher plate and stud (13). **NOTE:** Refer to the quantity of diaphragms (20) incorporated per the bill of materials listing. Depending on outlet pressure level, various quantities of metal diaphragms will be “stacked”.
15. Inspect pressure plate (3) to ensure no deformation due to over-pressurization. If deformed, bent, or otherwise distorted, replace.
16. Ensuring that the curved outer rim of the pressure plate (3) rests against the diaphragm (20) directly, place the pressure plate (3) over the pusher plate and stud (13). Place nut (11) onto the stud (13) and tighten. Recommended torques are as follows:

Body Size	Brass Trim Metal/Comp Diaphragm	Stainless Trim	
		Metal Diaphragm	Comp. Diaphragm
1/2"	25-30 ft-lbs	45-50 ft-lbs.	25-30 ft-lbs.
3/4" – 1-1/4"	35-45 ft-lbs	45-50 ft-lbs.	35-45 ft-lbs.
1-1/2" & 2"	50-60 ft-lbs	80-90 ft-lbs.	50-60 ft-lbs.
DN15	34-41 N-m	61-68 N-m	34-41 N-m
DN20-DN32	47-61 N-m	61-68 N-m	47-61 N-m
DN40-DN50	68-81 N-m	108-122 N-m	68-81 N-m

CAUTION

(DO NOT USE FINGERS TO HOLD DIAPHRAGMS (20) DURING TIGHTENING OF NUT (11).) Use two flange bolts (8) to keep multiple diaphragms (20) bolt holes properly aligned while tightening the stud nut (10).

17. Remove cotter pin (15) securing stud nut (10) to lower end of pusher plate and stud (13), and replace with a new pin (15). **(Do not allow the stud nut (10) to move when the cotter pin (15) is removed.)**
18. Remove rocker arm shaft (17) and rocker arm (14). Measure inside of rocker arm (14) "prongs" as indicated below:

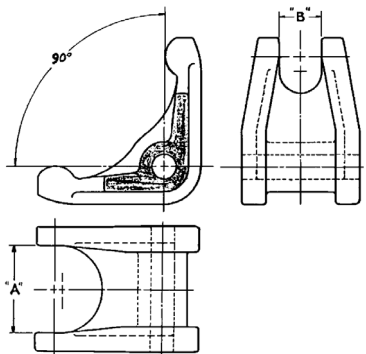

DIM	MAT'L	Valve Size					
		1/2"	(DN15)	3/4"	(DN20)	1"	(DN25)
A	BRZ	7/8"	(22mm)	1-5/32"	(29mm)	1-7/16"	(37mm)
B	BRZ	5/8"	(16mm)	25/32"	(20mm)	3/4"	(20mm)
A	SST	13/16"	(21mm)	1-1/16"	(27mm)	1-7/16"	(37mm)
B	SST	9/16"	(14mm)	23/32"	(18mm)	3/4"	(20mm)
DIM	MAT'L	1-1/4"	(DN32)	1-1/2"	(DN40)	2"	(DN50)
A	BRZ	1-13/16"	(46mm)	1-25/32"	(45mm)	2-3/16"	(56mm)
B	BRZ	29/32"	(23mm)	7/8"	(22mm)	29/32"	(23mm)
A	SST	1-1/2"	(38mm)	1-25/32"	(45mm)	2-5/32"	(55mm)
B	SST	11/16"	(17mm)	7/8"	(22mm)	29/32"	(23mm)

If any of the above dimensions are exceeded by 1/8" (3 mm), replace rocker arm (14).

19. Check rocker arm shaft (17) for wear and straightness. Replace if damaged. Reinstall in body (1) through rocker arm (14). Apply thread sealant to the rocker arm shaft (17) threads prior to tightening. Make sure that the rocker arm shaft (17) enters the support slot opposite the threaded opening, and does not align crooked and restrained from full thread engagement of the rocker arm shaft (17). Make sure that the rocker arm (14) prongs that straddle the piston (24) hold the piston collar (23) against the piston (24); do not allow the rocker arm (14) prongs to push directly on the piston (24).
20. Clean the body (1) diaphragm flange. Install a new diaphragm gasket (19). Composition (soft) diaphragms require no diaphragm gasket. **NOTE: Use only gaskets manufactured by Cashco, Inc., that are of the same material**

as those originally supplied. Substitution may cause improper gasket compression. It may also adversely change the diaphragm setting, which will affect the unit's performance, i.e. Option 1000-45, non-asbestos construction utilizes special gaskets.

21. Using small gauge wire approximately 18" (500 mm) long, form a hook and place the hook over one prong of the rocker arm (14), and rotate the rocker arm (14) up until slack is removed in the mechanism. Secure the wire through a body (1) flange bolt hole on the outlet side of the regulator.
22. Take the diaphragm sub-assembly (Step 16) and lower it down into the body (1) cavity off-center approximately 3/4"-1" (20-25 mm) and towards the inlet side of the regulator. When fully lowered, slide the diaphragm sub-assembly horizontally towards the regulator's outlet. The wire of Step 21 should hold the rocker arm (14) up to allow engaging of the pusher plate and stud (13) (with stud nut (10) and stud collar (16)), so the rocker arm (14) prongs rest directly on the stud collar (16). **(Do not allow the rocker arm (14) prongs to get between the stud nut (10) and the stud collar (16).)** Pull firmly to remove wire holding rocker arm (14) up.
23. Align diaphragm (20) bolt holes with body (1) flange bolt holes. Set range spring (27) onto pressure plate (3), place spring button (4) on top of range spring (27). Place multi-purpose, high temperature grease into depression of spring button (4).
24. Aligning the matchmarks, place spring chamber (2) over the above stacked parts. Install all bolts (8), nuts (9) and nameplate (28) by hand tightening. Tighten bolting (8 and 9) in a cross pattern that allows spring chamber (2) to be pulled down evenly. Recommended torques are as follows:

Body Size	Bolt Size	All Diaphs.*-Torque
1/2" (DN15)	3/8"	25 ft-lbs. (34 N-m)
3/4" (DN20)	7/16"	35 ft-lbs. (47 N-m)
1" (DN25)	1/2"	45 ft-lbs. (61 N-m)
1-1/4" (DN32)	1/2"	45 ft-lbs. (61 N-m)
1-1/2" (DN40)	9/16"	80 ft-lbs. (108 N-m)
2" (DN50)	5/8"	80 ft-lbs. (108 N-m)

* Minimum recommended torque regardless of gasket materials. Some gasket materials may require higher bolt torques to obtain adequate seal. Gasket material may take a "set" with time; a recheck of torques should be made if the unit has been stored on the shelf for over 30 days.

NOTE: Never replace bolting (8 and 9) with just any bolting if lost. Bolt heads and nuts are marked with specification identification numbers. Use only proper grades as replacements.

25. Reinstall adjusting screw (6) with locknut (7); install closing cap (31) if provided.
26. Soap solution test around bolting (8 and 9), body (1), spring chamber (2) flanges, and cylinder (21)-to-body (1) joint for leakage. Ensure that an outlet pressure is maintained during this leak test of at least mid-range spring level; i.e. 10-40 psig (0.7-2.75 Barg) range spring, 25 psig (1.75 Barg) test pressure minimum. Use 100 psig (7.0 Barg) minimum inlet pressure to leak test. Actual service conditions should be used if in excess of the minimum conditions.

C. Special Instructions for Diaphragm Removal.

1. If Option 1000-3, Handwheel or Tee-bar, is utilized, the adjusting screw (6) and locknut (7) are replaced respectively by handwheel/tee-bar adjusting screw (6) and locking lever (7).
2. Use only gaskets of the same material as those originally utilized. Cashco's Option 1000-45, non-asbestos construction, utilizes special gaskets.

D. Diaphragm Setting Adjustment:

1. In the previous "Sub-Section B. Diaphragm Replacement", care was taken to prevent removal of the stud collar (16) and stud nut

(10). Location of the stud nut (10) is a critical adjustment for a Model 1000 regulator.

2. Not removing the stud nut (10) will provide performance equal to original factory performance when a diaphragm(s) (20) is replaced with a like diaphragm(s) (20). However, if the stud nut (10) is removed, or a switch is made from metal to composition diaphragm (20), or vice versa, the diaphragm setting should be checked.

3. Follow procedure "Sub-Section B. Diaphragm Replacement" to the point of removing diaphragm(s) (20), Step 14. Remove diaphragm gasket (19) and pusher plate stud gasket (12). Obtain a flat 12" x 1-1/2" x 1/4" (300 mm x 40 mm x 6 mm) plate bar with a 3/4" (20 mm) hole drilled in the center. Hook the pusher plate stud (13) into the rocker arm (14) prongs properly. Pull firmly up on the pusher plate stud (13) to ensure that all slack is removed from the mechanism and that the piston (24) is seated firmly. Relax the pulling and place the flat bar over the pusher plate stud (13) with the stud (13) passing through the hole of the bar. Again, pull firmly up to remove mechanism slack. One of three positions will be reached:

- a. Diaphragm setting too high. Pusher plate stud (13) will lift the flat bar over 0.020" (0.50 mm).
- b. Diaphragm setting acceptable. Bar lifted between 0.010"-0.020" (0.25-0.50 mm).
- c. Diaphragm setting too low. Bar lifted less than 0.010" (0.25 mm), or failed to be lifted.

4. The castle style stud nut (10) has six locations per revolution to align the stud nut (10) slots with the drilled hole through the pusher plate stud (13). Each stud nut (10) slot represents a movement up/down of 0.010" (0.25 mm). **NOTE:** The ideal diaphragm setting is 0.015" (0.38 mm) high, and better performance is usually obtained when the diaphragm is slightly higher rather than lower. As the measuring of thousandths of an inch is difficult with such a procedure, it is recommended that the "null" position be found where the diaphragm (20) is flush with the body (1) flange (bar approximately at 0.000" (0.00 mm)). Remove the pusher plate stud (13), rotate the stud nut (10) one or two slots CCW to bring the setting to 0.010"-0.020" (0.25-0.50 mm) high.

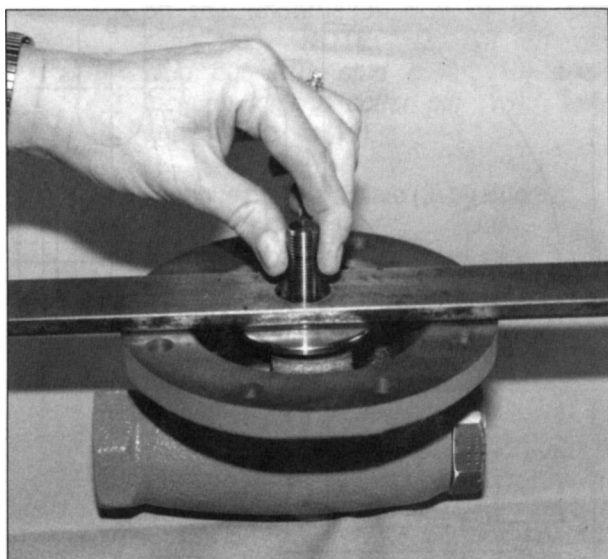

Checking diaphragm setting.

5. Place cotter pin (15) through the slot/hole, bend over ends.
6. Continue reassembly per Sub-Section B. Diaphragm Replacement, Step 14.

E. Trim Removal and Replacement

1. Install body (1) horizontally in a vise with the spring chamber (2) directed upwards, and the body (1) held at the outlet end.
2. Use a box end wrench or socket, with a lever length of at least 24 inches (600 mm), and place it over the hex surfaces of the cylinder (21). The wrench should be rapped with a hammer to loosen.

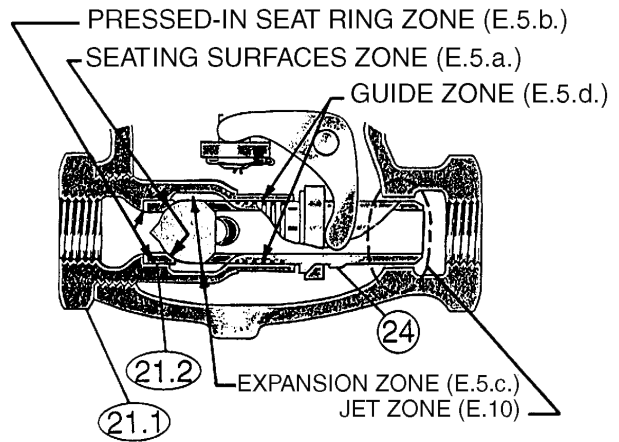

**CYLINDER SUB-ASSEMBLY (21) WITH
PISTON (24) — METAL SEATED
CONSTRUCTION**



CAUTION

Take precaution to not allow the piston (24) to fall from within the cylinder (21); tip cylinder with hex end down.

3. Continue to unscrew cylinder (21) until removed. The piston (24) and piston collar (23) should come out by gravity with the cylinder (21) removal.
4. If an Option 1000-17 piston spring (30) is utilized, it also should be removed and replaced at trim replacement.
5. Inspect inside surface of cylinder (21) at four points:
 - a. Valve seat (21.2). Check for erosion/wear on seating surfaces. If wear is excessive, consider utilizing Option 1000-15, stellited seat surfaces.
 - b. Seat (21.2). Check for wire drawing between cylinder (21.1) and valve seat (21.2) where pressed in. If wear exists here, an Option 1000-14, integral seat, should be utilized as a replacement.
 - c. Flow induced wear at expansion zone where fluid turns to enter the piston (24) center.
 - d. Where the piston (24) ribbed guides bear (guide zone).

If wear is significant at any of these points, both cylinder sub-assembly (21) and piston sub-assembly (24 or 24, 25 and 26) should

be replaced. (Cashco, Inc., does not recommend attempting to replace the valve seat (21.2) by pressing out and then re-pressing in. Cashco, Inc., also recommends that a cylinder (21) and piston (24 or 24, 25 and 26) be replaced as a set. Composition seat discs (25) may be replaced individually.)

6. If a composition (soft) seat trim design is utilized, use the following sub-steps:
 - a. Tighten the “flats” of the seat disc screw (26) within a vise. Firmly hand-grip the piston (24) and turn CCW to loosen the seat disc screw (26). If too tight, place a screwdriver or similar rod within the piston (24) port holes and rotate. Remove the piston (24), and inspect for raised burrs around the port holes if a device is used to loosen; deburr as required. **NOTE: Do not grip the piston (24) with a wrench.**
 - b. Remove the seat disc (25) and clean the recessed piston (24) area where the seat disc (25) is placed. If the edges which form the recess of the piston (24) are worn, also replace piston (24) and seat disc screw (26).
 - c. Place seat disc (25) into recessed end of piston (24).
 - d. Place thread sealant on threaded portion of seat disc screw (26), and manually rotate piston (24) into seat disc screw (26) (still fixed in vise) to secure seat disc (25). Tighten seat disc screw (26) firmly. Do not over-tighten to the point of embedding

the seat disc screw (26) into the seat disc (25); the seat disc (25) should lay flat with no rounded surface. A mechanical aid is normally not required; hand-tightening is normally sufficient.

7. If utilized, place piston spring (30) over smaller end of cylinder (21).
8. Insert piston assembly (24 metal seat; 24, 25 and 26 comp. seat) into end of cylinder (21).
9. Place piston collar (23) over end of piston (24), ensuring that the spherical surface of the piston (24) and the piston collar (23) bear against each other.
10. Clean the body (1) cavity through the openings. Clean the "jet area" just inside the body (1) outlet end through which the piston (24) projects. Clean all parts to be reused. **NOTE:** *On valves originally supplied with Option 1000-55, "oxygen clean", maintenance must include a level of cleanliness equal to Cashco, Inc's., cleaning standard #S-1134. Contact factory for details.*
11. Use special care cleaning the flat mating surfaces of the body (1) and cylinder (21) shoulder, as this pressurized joint is metal-to-metal with no gasket.

12. Lubricate the cylinder (21) threads lightly with thread sealant. Insert the entire trim stack into the body (1) opening and screw until tightly seated. Using the hammer and wrench handle, impact the cylinder (21) into the body (1). **NOTES:** *1. Take special precaution to keep piston collar from getting "cocked" at an angle when inserted. 2. On 2" brass bodies (1) with brass trim, a TFE body O-ring (43) is utilized to seal between the body (1) and the cylinder (21) sub-assembly.*
13. Inspect the body (1) outlet end to ensure that the piston (24) is located nearly concentric to the body (1) bore in the jet area with clearance. Under no conditions should the piston (24) be touching the body (1). Use two pencils or similar shafts to place in inlet and outlet ends of regulator and alternately push on each end of the piston (24) to ensure free movement. (Total movement is approximately 1/8" (3 mm).)
14. Bench test unit for suitable operation and seat leakage. **NOTE:** *Regulators are not normally tight shutoff devices. Pressure must build above setpoint for best shutoff.*
15. Soap solution test around cylinder (21)-to-body (1) connection for leakage. Test pressure should be a minimum of 100 psig (7.0 Barg) at the inlet, or actual service conditions if higher.

SECTION VII

VII. TROUBLE SHOOTING GUIDE:

1. Erratic operation, chattering.	
Possible Causes	Remedies
A. Oversized regulator; inadequate rangeability.	A1. Check actual flow conditions, resize for minimum and maximum flow. A2. Increase flow rate. A3. Decrease pressure drop; decrease inlet pressure by placing a throttling orifice in inlet piping union. A4. Replace full orifice with reduced orifice; i.e. new cylinder required.
B. Worn piston/cylinder; inadequate guiding.	B. Replace trim.
C. Flow induced instability.	C1. Get straight runs of piping (5 diameters upstream, 10 downstream) to and from regulator. C2. Ensure outlet velocity is not excessive; use pipe reducer close to regulator outlet. C3. Add next higher range spring. Contact factory. C4. If composition diaphragm, switch to metal diaphragm.
D. Improper (oversized) jet.	D. Replace existing piston with new piston with proper jet.
E. Plugged trim.	E. Remove trim and check for plugged holes in piston, or debris in guide zone or jet zone.

2. Regulator outlet (downstream) pressure too low.	
Possible Causes	Remedies
A. Setpoint too low.	A. Turn adjusting screw down (CW) to increase setpoint.
B. Regulator undersized.	B1. Confirm by opening bypass valve together with regulator. B2. Check actual flow conditions, resize; if regulator has inadequate capacity, replace with larger unit.
C. Plugged inlet strainer.	C. Remove strainer screen and clean; consider leaving screen out.
D. Plugged trim.	D. Remove trim and check for plugged holes in piston, or debris in guide zone or jet zone.
E. Incorrect range spring (turning adjusting screw CW does not allow bringing pressure level up to proper level).	E. Replace range spring with proper higher range. Contact factory.
F. Too much droop.	F1. Review droop expected. (See 2.B1 above.) F2. Diaphragm setting too low; check setting and raise as required. F3. Consider composition diaphragm over metal. F4. Improper jet; make sure jet matches actual fluid.
G. Restricted diaphragm movement (pressure plate hitting upstops)	G1. Diaphragm setting too high; check and lower as required. G2. Ensure no moisture in spring chamber at temperatures below freeze point. Ensure no dust or debris entering vent opening. If rainwater or debris can enter, reorient spring chamber.
H. Restricted diaphragm movement (overstretched diaphragm).	H1. Diaphragm setting too low; check and increase as required. H2. Ensure no moisture in spring chamber at temperatures below freeze point. Ensure no dust or debris entering vent opening. If rainwater or debris can enter, reorient spring chamber.

3. Leakage through the spring chamber vent hole.	
Possible Causes	Remedies
A. Normal-life diaphragm failure.	A. Replace diaphragm.
B. Abnormal short-life diaphragm failure.	B1. Can be caused by excessive chattering. See No. 1 to remedy chatter. B2. Can be caused by corrosive action. Consider alternate diaphragm material. B3. For composition diaphragms, ensure not subjecting to over-temperature conditions. B4. Downstream (outlet) pressure buildup occurring that overstresses diaphragms.
C. Pusher plate gasket leaking.	C. Replace gasket.
D. Improper (oversized) jet.	D. Replace existing piston with new piston with proper jet.
E. Plugged trim.	E. Remove trim and check for plugged holes in piston, or debris in guide zone or jet zone.

4. Excessive pressure downstream.	
Possible Causes	Remedies
A. Regulator not closing tightly.	A1. Overly compressed range spring; i.e. approaching solid height. Use next higher range spring. A2. Inspect the seating. Clean and lap metal seat surfaces; replace if lapping does not remedy. If composition seats are depressed, nicked or embedded with debris, replace seat disc. A3. Diaphragm setting too high; check setting. A4. Inlet pressure too high for orifice size; check permissible inlet (P_1) pressure level for a given outlet. Change to reduced port if required. A5. Leakage past pressed in valve seat ring; consider integral seat. A6. When diaphragm sub-assembly was put into place, the rocker arm got between the stud collar and the stud nut rather than on top of the stud collar.
B. Downstream block.	B. Check system; isolate (block) flow at regulator inlet, not outlet. Relocate regulator if necessary.
C. No pressure relief protection.	C. Install safety relief valve, or rupture disc.
D. Restricted diaphragm movement.	D1. Diaphragm setting too high; check and lower as required. D2. Ensure no moisture in spring chamber at temperatures below freeze point. Ensure no dust or debris entering vent opening. If rainwater or debris can enter, reorient spring chamber.

5. Sluggish operation.	
Possible Causes	Remedies
A. Plugged spring chamber vent.	A. Clean vent opening.
B. Plugged piston or jet zone.	B. Remove trim and clean.
C. Fluid too viscous.	C. Heat fluid.
D. Improper (undersized) jet.	D. Replace existing piston with new piston for viscous service; i.e. Option 1000-27.

6. Frequent resetting of setpoint.	
Possible Causes	Remedies
A. Over-pressurization downstream resulting in: 1. Bent metal diaphragm(s). 2. Sprung rocker arm. 3. Range spring overstressed/fatigued.	A1. Replace diaphragms. Correct potential source of downstream overpressure. A2. Check measurements of rocker arm. Replace if necessary. A3. Replace range spring; consider next higher range spring.

SECTION VIII

VIII. ORDERING INFORMATION: NEW REPLACEMENT UNIT vs PARTS "KIT" FOR FIELD REPAIR

To obtain a quotation or place an order, please retrieve the Serial Number and Product Code that was stamped on the metal name plate and attached to the unit. This information can also be found on the Bill of Material (parts list) that was provided when unit was originally shipped.) (Serial Number typically 6 digits). Product Code typical format as follows: (last digit is alpha character that reflects revision level for the product).

□□□□ - □□□□ 7 - □□□□□□□□□□

NEW REPLACEMENT UNIT:

Contact your local Cashco, Inc., Sales Representative with the Serial Number and Product code. With this information they can provide a quotation for a new unit including a complete description, price and availability.

PARTS "KIT" for FIELD REPAIR:

Contact your local Cashco, Inc., Sales Representative with the Serial Number and Product code. Identify the parts and the quantity required to repair the unit from the Bill of Materials sheet that was provided when unit was originally shipped.

CAUTION

Do not attempt to alter the original construction of any unit without assistance and approval from the factory. All purposed changes will require a new name plate with appropriate ratings and new product code to accommodate the recommended part(s) changes.

NOTE: *Those part numbers that have a quantity indicated under "Spare Parts" in column "A" reflect minimum parts required for inspection and rebuild, - "Soft Goods Kit". Those in column "B" include minimum trim replacement parts needed plus those "Soft Goods" parts from column "A".*

If the "BOM" is not available, refer to the cross-sectional drawings included in this manual for part identification and selection.

Local Sales Representative will provide quotation for appropriate Kit Number, Price and Availability.

Basic Valve with Metal Seat Construction, Brass Trim

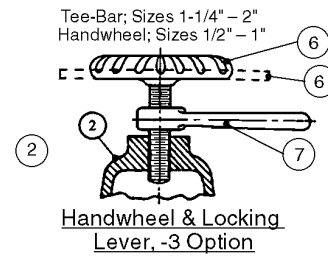
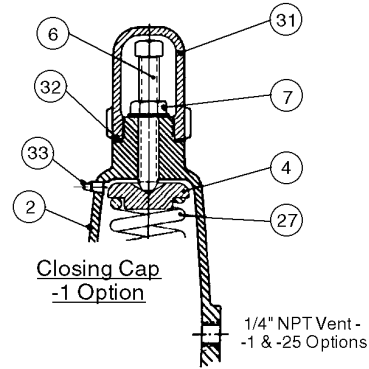
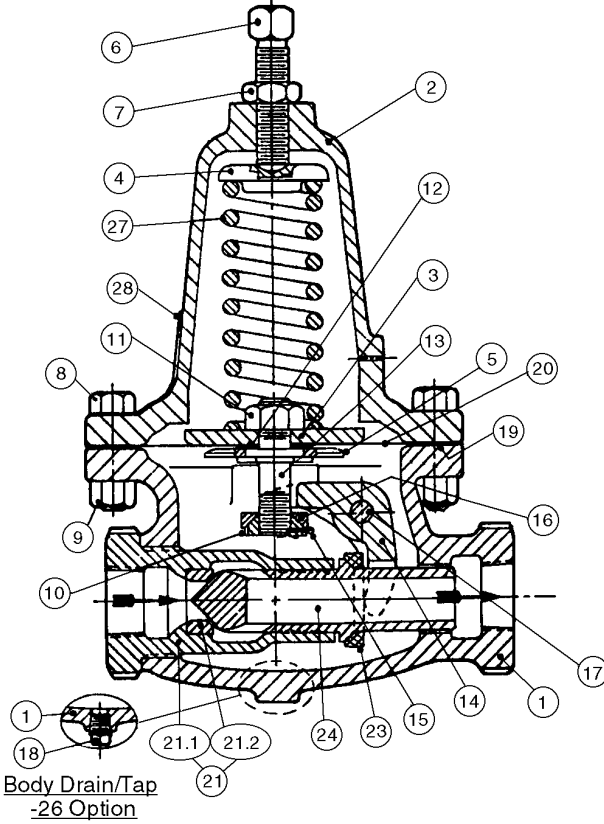

ITEM NO.	DESCRIPTION	ITEM NO.	DESCRIPTION
1.	BODY & BODY ASSY	16.	STUD COLLAR
2.	SPRING CHAMBER	17.	ROCKER ARM SHAFT
3.	PRESSURE PLATE	18.	BODY PLUG
4.	SPRING BUTTON	19.	DIAPHRAGM GASKET
5.	PUSHER PLATE	20.	DIAPHRAGM(S)
6.	ADJUSTING SCREW	21.	CYLINDER ASSEMBLY
6.	HANDWHEEL ASSY (-3 OPT)	21.1	CYLINDER
6.	TEE-BAR ASSY (-3 OPT)	21.2	VALVE SEAT
7.	ADJUSTING SCREW LOCK NUT	23.	PISTON COLLAR
7.	LOCKING LEVER (-3 OPT)	24.	PISTON
7.	SEALING LOCK NUT (-1 OPT)	25.	SEAT DISC
8.	FLANGE BOLT	26.	SEAT DISC SCREW
9.	FLANGE NUT	27.	RANGE SPRING
10.	STUD NUT	28.	NAME PLATE
11.	PRESSURE PLATE NUT	29.	SEAT CONE (-15 OPT)
12.	PUSHER PLATE GASKET	30.	PISTON SPRING (-17 OPT)
13.	PUSHER PLATE STUD	31.	CLOSING CAP (-1 OPT)
14.	ROCKER ARM	32.	CLOSING CAP GASKET (-1 OPT)
15.	COTTER PIN	33.	SPRING CHAMBER PIPE PLUG (-1 OPT)

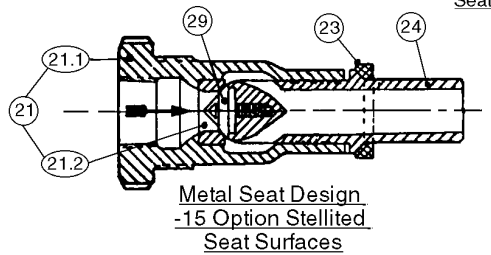
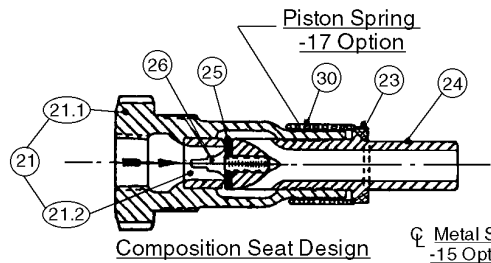
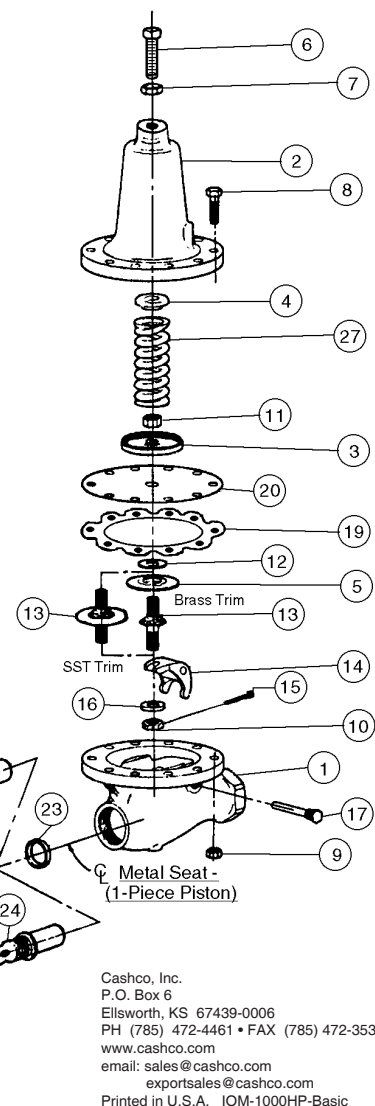

☉ Metal Seat Design
-15 Option Stellited
Seat Surfaces

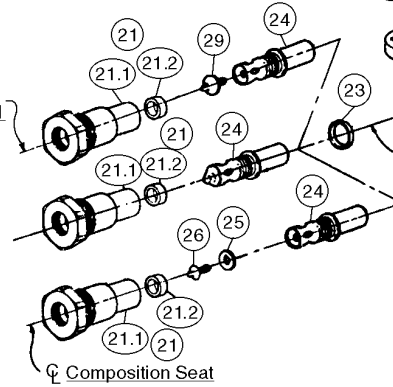

Cashco, Inc.
P.O. Box 6
Ellsworth, KS 67439-0006
PH (785) 472-4461 • FAX (785) 472-3539
www.cashco.com
email: sales@cashco.com
exportsales@cashco.com
Printed in U.S.A. IOM-1000HP-Basic